

QUALITROL® TWP and JBox

Junction box and tank wall plate



Reliable protection of fiber optic connections

- Easy installation
- Quick access to fibers connections
- Junction box mates with all QUALITROL tank wall plates

Product Summary

Description Designed for prolonged protection of fiber optic components in any environment. Removable panel for easy access to connections without removal of entire junction box and conduit. Tank wall plates (TWP) available in bolt-on and weld-on versions.

Number of holes in tank wall plate are customer specified and designed to mate with optical feedthroughs (OFT).

Application Protection of fiber optic connections at the tank wall of oil-filled or dry-type power transformers.

Fibers by 



QUALITROL®

Defining Reliability



TWP Transformer tank wall outing plate optical feedthroughs

Up to 16 feedthroughs on the same TWP plate

- The tank wall plate accommodates from 1 to 16 optical feedthroughs and is supplied with plugs to close unused holes. It comes standard with 1/4 NPT ANSI threads. ISO threads are also available.
- Each NPT hole is numbered on both sides of the plate using a deep engraving technique allowing perfect reading of numbers even after being painted. Moreover, both interior and exterior sides are engraved.

Made of carbon or stainless steel

- As a standard item, the TWP is made out of cold finished 1018 steel (ASTM A108). If needed, it can also be manufactured using any other material, including stainless steel 316.
- Flat surface for quick, easy and leak-free conduit installation

Can be welded or bolted

- The TWP can be welded directly on the tank wall. It can be delivered with two tapered 10-24 UNC holes for clamping the TWP during welding process. The tank wall plate is also available upon request with eight unthreaded holes for direct bolting, with gasket or O-ring, onto the tank wall.

Can be custom made

- Neoptix has an extensive bank of CAD drawings of many different models of Tank Wall Plates that can fulfill your needs. Contact Neoptix for more details.



Dimensions:
(Other dimensions, material and feedthrough number available)

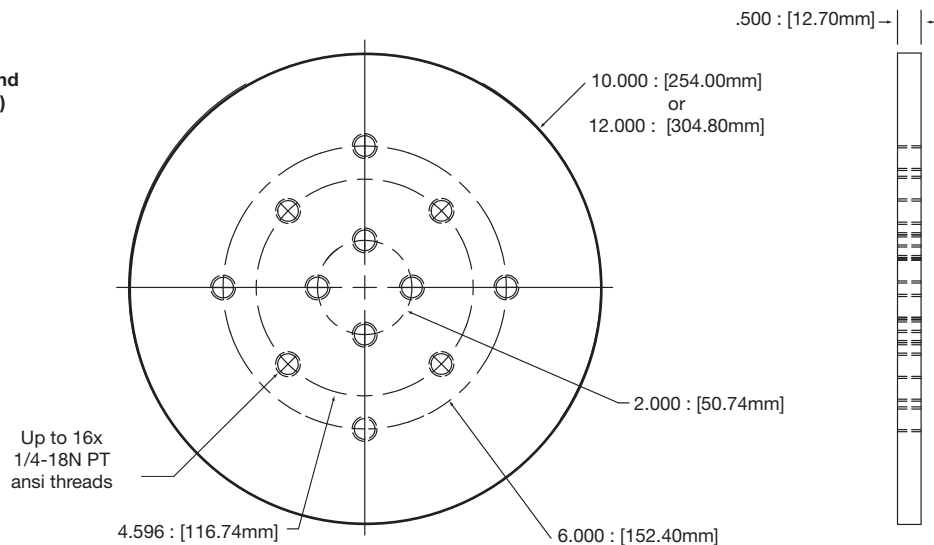



Junction Box

Reliable protection of fiber optic connections

- Eliminates need for drilling additional holes or welding to create a 'do-it-yourself' solution for protection of fiber optic connections.
- Two specially designed 1/8 inch (3.2mm) thick neoprene gaskets (one for access panel and one for base of junction box) isolate optical feedthroughs (OFT) and fiber optic extension cables (EXT) from harsh environmental conditions

Easy installation

- Access panel makes installation and connections easy
- Flat surface for quick, easy and leak-free conduit installation

Junction box mates with all QUALITROL tank wall plates

- Junction box designed to perfectly mate with either bolt-on or weld-on tank wall plates

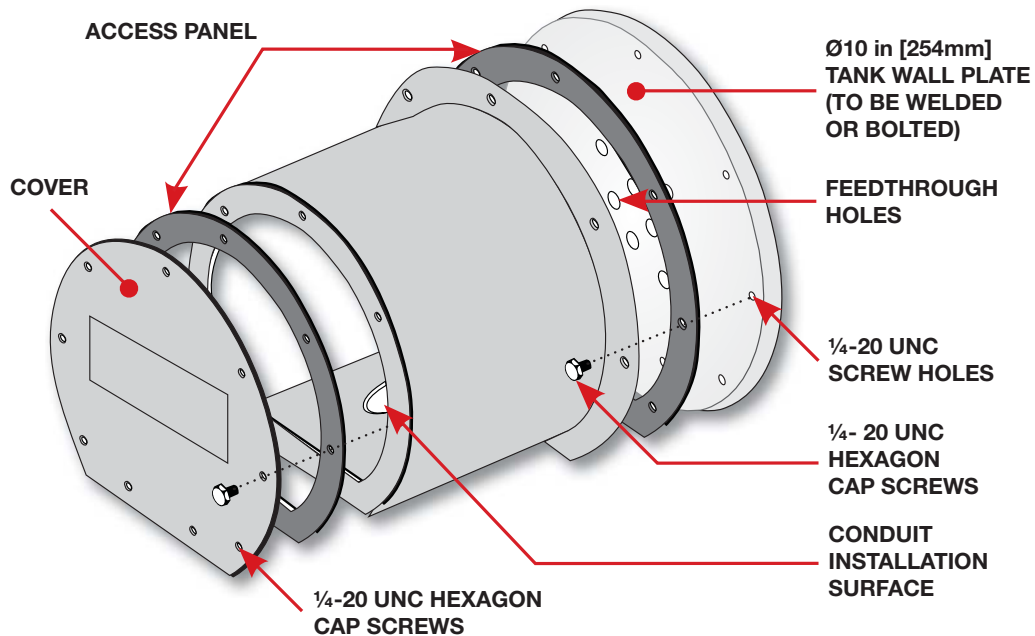



TECHNICAL SPECIFICATIONS

Tank wall plate	Material	Standard: 1018 cold rolled steel, 0.5 inch (12.5mm) thick Standard Cold Finished 1018 Steel (ASTM A108) Optional: Other material such as Stainless Steel 316
	Number of feedthroughs	Up to 16 NPT-F drilled and tapped holes.
	Dimension:	Standard: Ø10 inches, 0.5 inch (12.5mm) thickness Optional: Ø12 inches, 0.5 inch (12.5mm) thickness
	Mounting	Standard: Direct welding onto tank wall Optional: Bolting threads with or without recess for gasket (32 rms)
	Mounting clamps:	Standard: Standard: none Optional: Tapered 10-24 UNC holes (2x) for clamping
	NPT Type:	Standard: NPT 1/4-18, ANSI threads Optional: NPT 3/8-XX, ANSI threads
	Compatibility:	Compatible with Neoptix OFT optical feedthroughs
	Option:	NXP-611: Installation of OFT's on TWP and testing to 7 bar

Ordering code:

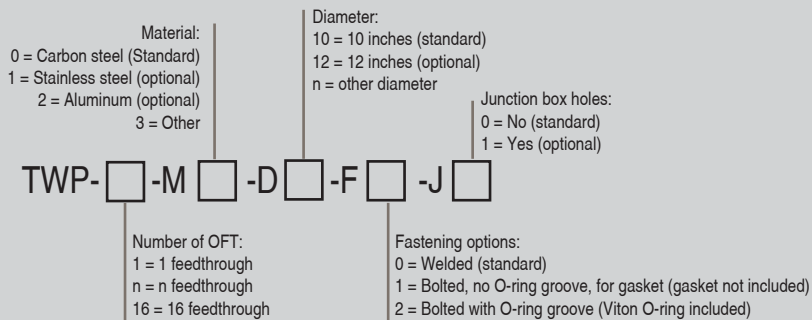

Junction box	Conduit installation surface	5.5 inches x 6.0 inches (140mm x 152mm) Hole to be made by user, as required
	Gaskets	Two 1/8 inch (3.2mm) thick neoprene gaskets.
	Material	14 gauge carbon or stainless steel
	Mounting	Bolted to tank wall plate (9 x 1/4 -20- UNC hexagon cap screws)
	Finish	ASA61 polyurethane enamel paint (carbon steel only) Stainless steel (unpainted)
	Access panel	Removable panel (9 x 1/4 -20 UNC hexagon cap screws)

About QUALITROL®

QUALITROL manufactures substation transformer monitoring and protection devices used by electric utilities and manufacturing companies. It is the global leader in sales and installations of transformer asset protection equipment, fault recorders and fault locators. Established in 1945, QUALITROL produces thousands of different types of products on demand, each customized to customers' unique requirements.

©2008-2011 QUALITROL® Company LLC, an ISO 9001 system certified company. All rights reserved. Information subject to change without notice. All trademarks are properties of their respective companies, as noted herein. AP-M09-16L-01F.