

**CERAMIC BUSHING
INSULATORS**
FOR OIL-INSULATED
TRANSFORMERS

comem[®]

CERAMIC BUSHING INSULATORS FOR OIL-INSULATED TRANSFORMERS

Comem S.p.A. has been producing transformer insulators since 1964, gradually developing other products and product lines and acquiring solid experience in many fields in Italy and all over the world.

Today Comem S.p.A. is increasing its new products research and development efforts to meet growing market demand and increasingly complex requirements. Comem offers to its customers excellent quality, fast service and also expert collaboration that is abreast of the times. This catalogue gives as much information as possible concerning the electrical characteristics and dimensions of ceramic bushing insulators for transformers.

All drawings and the related components are numbered for quick and correct identification of each part.

The catalogue is divided into three sections:

- Ceramic insulators for low voltage applications **(A)**
- Ceramic insulators for medium voltage applications **(B)**
- Connecting flags for insulators **(C)**

All metal parts are made using the most advanced machining and pressing technologies.

All insulators are subjected to electrical tests in compliance with current IEC standards.

Machining tolerances and the characteristics of raw materials comply with UNEL, DIN, CENELEC and UNE standards.

This catalogue does not include all the products we can supply.

We invite our customers, in case of special requirements or needs, to contact our business and engineering departments.

GENERAL INDEX

A

CERAMIC INSULATORS FOR LOW VOLTAGE APPLICATIONS

INSULATION CLASS
1 ÷ 3 kV
RATED CURRENT
250 ÷ 6500 A

	ACCORDING	NOMINAL VOLTAGE	RATED CURRENT	NO. PAGE
A₁	DIN 42530-68 • DIN 42539-68	1 ÷ 3 kV	250 A ÷ 630 A	06-07
A₂	DIN 42530-68 • DIN 42539-68	1 ÷ 3 kV	1000 A ÷ 3150 A	08-09
A₃	EN 50386	1 kV	250 A Solution "A"	10-11
A₄	EN 50386	1 kV	250 A Solution "B"	12-13
A₅	EN 50386	1 kV	630 A Solution "A"	14-15
A₆	EN 50386	1 kV	630 A Solution "B"	16-17
A₇	EN 50386	1 kV	1250 A Solution "A"	18-19
A₈	EN 50386	1 kV	1000 A ÷ 1250 A Solution "B"	20-21
A₉	EN 50386	1 kV	2000 A ÷ 5000 A	22-23
A₁₀	COMEM	3 kV	4500 A	24-25
A₁₁	COMEM	3 kV	6500 A	26-27
A₁₂	ORDER SHEET	—	—	28

B

CERAMIC INSULATORS FOR MEDIUM VOLTAGE APPLICATIONS

INSULATION CLASS
12 ÷ 52 kV
RATED CURRENT
250 ÷ 8000 A

	ACCORDING	NOMINAL VOLTAGE	RATED CURRENT	NO. PAGE
B₁	DIN 42531	12 kV ÷ 36 kV	250 A	30-31
B₂	DIN 42532	12 kV ÷ 36 kV	630 A	32-33
B₃	DIN 42533	12 kV ÷ 36 kV	1000 A ÷ 3150 A	34-35
B₄	DIN 42534	52 kV	1000 A ÷ 3150 A	36-37
B₅	EN 50180	12 kV ÷ 36 kV	250 A	38-39
B₆	EN 50180	12 kV ÷ 36 kV	630 A	40-41
B₇	EN 50180	12 kV ÷ 36 kV	1250 A ÷ 3150 A	42-43
B₈	COMEM	36 kV	250 A	44-45
B₉	COMEM	52 kV	250 A ÷ 630 A	46-47
B₁₀	COMEM	24 kV	6300 A	48-49
B₁₁	COMEM	12 kV ÷ 36 kV	4500 A	50-51
B₁₂	COMEM	52 kV	1000 A ÷ 3150 A	52-53
B₁₃	DIN 42541	24 kV ÷ 36 kV	5000 A ÷ 8000 A	54-55
B₁₄	EN 50243	24 kV ÷ 36 kV	5000 A ÷ 8000 A	56-57
B₁₅-B₁₆	FIXING INSTRUCTON	—	—	58-59
B₁₇	ORDER SHEET	—	—	60

C

CONNECTING FLAGS FOR INSULATORS

TYPE	ACCORDING	RATED CURRENT	PAGE	TYPE	ACCORDING	RATED CURRENT	PAGE
DP	DIN 43675-75	630 A	62	2-009	COMEM	250 A	68
DR	DIN 43675-75	630 A	62	AF 06	COMEM	630 A	68
EP	DIN 43675-75	1000 A	63	AF 1	COMEM	1000 A	69
ER	DIN 43675-75	1000 A	63	10-086	COMEM	1000 A	69
FP	DIN 43675-75	2000 A ÷ 3150 A	64	AF 2	COMEM	2000 A	70
FR	DIN 43675-75	2000 A ÷ 3150 A	64	20072	COMEM	2000 A	70
TP 78-120	DIN 43675-75	5000 A	65	AF 3	COMEM	3150 A	71
TP 78-180	DIN 43675-75	8000 A	65	31073	COMEM	3150 A	71
6	UNEL 38137-67	630 A	66	4500 A	COMEM	4500 A	72
10	UNEL 38137-67	630 A ÷ 1000 A	66	FR 4500	COMEM	4500 A	72
20	UNEL 38137-67	2000 A ÷ 3150 A	66	U/6300	COMEM	6300 A	73
31	UNEL 38137-67	2000 A ÷ 3150 A	66	L/6300	COMEM	6300 A	73
E/1000	UNE 20-176	1000 A	67	6500 A	COMEM	6500 A	74
E/2000	UNE 20-176	2000 A	67	5000 A	COMEM	5000 A	74
E/3150	UNE 20-176	3150 A	67	TP 5000	COMEM	5000 A	74

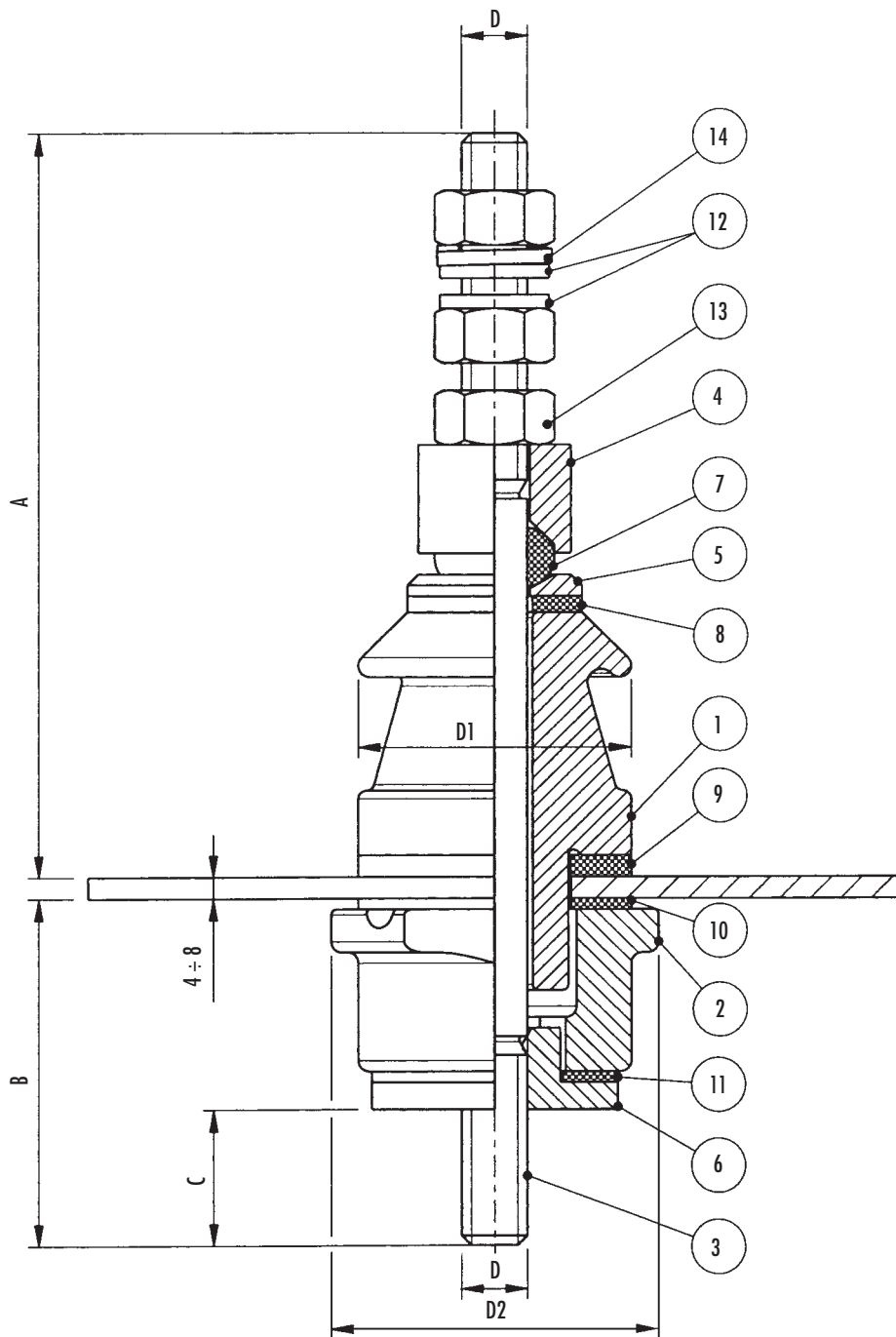

A₁**1 ÷ 3 kV****DIN 42530-68
DIN 42539-68****250 A ÷ 630 A**

TYPE	A (Max)	B	C	D	D1	D2	Tank Hole	Weight
1 kV / 250 A	138	68	25	M12	Ø 50	Ø 60	Ø 28	0.7 kg
3 kV / 250 A	180	94	25	M12	Ø 75	Ø 70	Ø 39	1.3 kg
1 kV / 630 A	178	82	37	M20	Ø 70	Ø 85	Ø 45	2.0 kg
3 kV / 630 A	210	110	37	M20	Ø 90	Ø 85	Ø 45	2.5 kg

DIN 42530-68
DIN 42539-68

1 ÷ 3 kV

A₁

250 A ÷ 630 A

ITEM	DESCRIPTION	Q.TY
1	UPPER PORCELAIN	1
2	LOWER PORCELAIN	1
3	BOLT	1
4	UPPER WASHER	1
5	MIDDLE WASHER	1
6	LOWER WASHER	1
7	GASKET	1
8	GASKET	1
9	GASKET	1
10	GASKET	1
11	GASKET	1
12	WASHER DIN 125 A	2
13	FULL NUT	3
14	WASHER DIN 127 B	1

IDENTIFICATION			VOLTAGE TIGHTNESS					
ACCORDING TO STANDARD	RATED VOLTAGE (kV)	RATED CURRENT (A)	LIGHTING IMPULSE (kV)	POWER FREQUENCY (kV)		CREEPAGE DISTANCE MIN. (mm)	ARCING DISTANCE MIN. (mm)	LEE PROTECTED LINE MIN. (mm)
				DRY	WET			
DIN 42530-68	1	250	—	—	—	60	50	10
DIN 42539-68	3	250	40	14	10	120	100	16
DIN 42530-68	1	630	—	—	—	75	60	10
DIN 42539-68	3	630	40	14	10	120	100	16

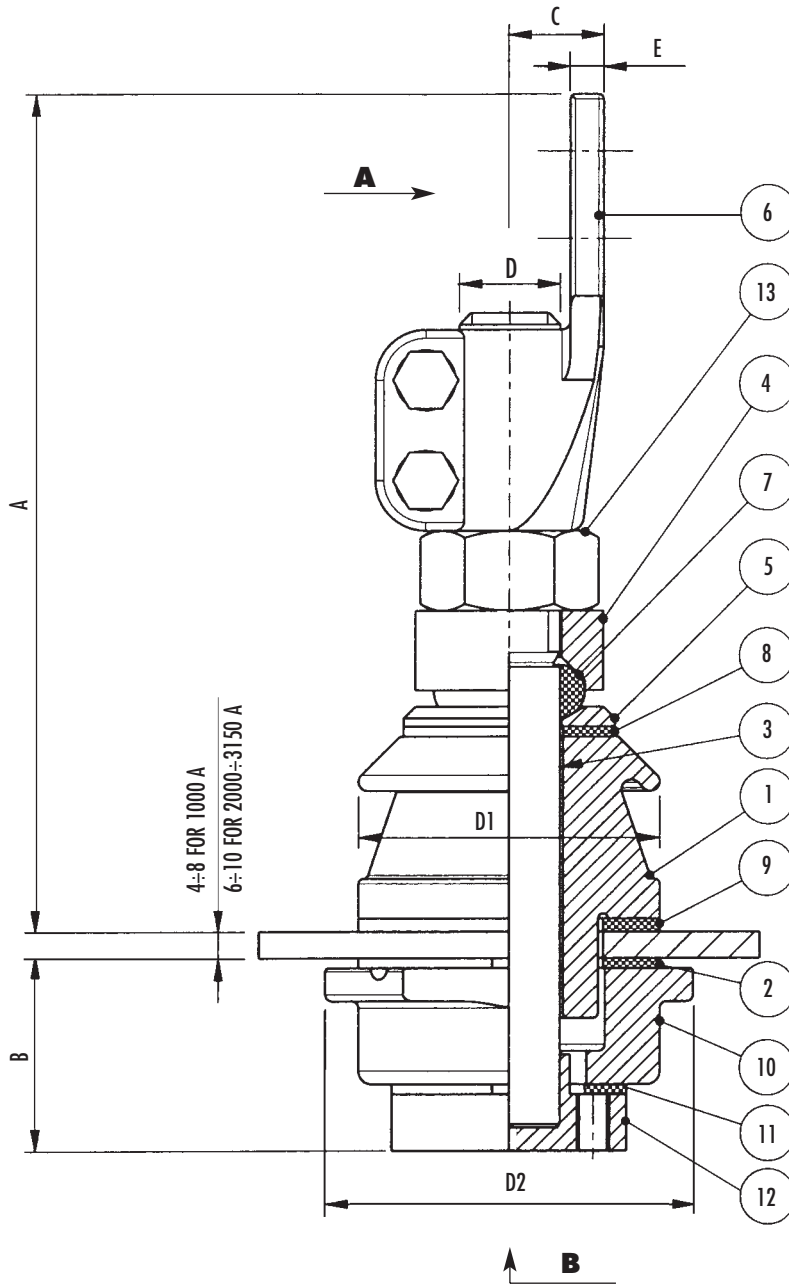

TYPE	A (Max)	B	C	D	D1	D2	E	Tank Hole	Weight
1 kV/1000 A	263	60	28	M30x2	∅ 90	∅ 110	10	∅ 56	4.9 kg
3 kV/1000 A	294	80	28	M30x2	∅ 110	∅ 110	10	∅ 56	5.8 kg
1 kV/2000 A	340	65	40	M42x3	∅ 104	∅ 125	15	∅ 70	11.7 kg
3 kV/2000 A	372	86	40	M42x3	∅ 125	∅ 125	15	∅ 70	13.0 kg
1 kV/3150 A	372	70	45	M48x3	∅ 125	∅ 150	15	∅ 90	15.8 kg
3 kV/3150 A	404	92	45	M48x3	∅ 145	∅ 150	15	∅ 90	17.5 kg

1000 A ÷ 3150 A

ITEM	DESCRIPTION	Q.TY
1	UPPER PORCELAIN	1
2	GASKET	1
3	BOLT	1
4	UPPER WASHER	1
5	MIDDLE WASHER	1
6	FLAG DIN 43675	1
7	GASKET	1
8	GASKET	1
9	GASKET	1
10	LOWER PORCELAIN	1
11	GASKET	1
12	LOWER WASHER	1
13	FULL NUT	1
14	WASHER DIN 125 A	2
15	SCREW DIN 933	2

IDENTIFICATION			VOLTAGE TIGHTNESS					
ACCORDING TO STANDARD	RATED VOLTAGE (kV)	RATED CURRENT (A)	LIGHTING IMPULSE (kV)	POWER FREQUENCY (kV)		CREPAGE DISTANCE MIN. (mm)	ARCING DISTANCE MIN. (mm)	LEE PROTECTED LINE MIN. (mm)
				DRY	WET			
DIN 42530-68	1	1000	—	—	—	75	60	10
DIN 42539-68	3	1000	40	14	10	125	100	16
DIN 42530-68	1	2000	—	—	—	75	60	10
DIN 42539-68	3	2000	40	14	10	125	100	18
DIN 42530-68	1	3150	—	—	—	75	60	10
DIN 42539-68	3	3150	40	14	10	125	100	18

A VIEW

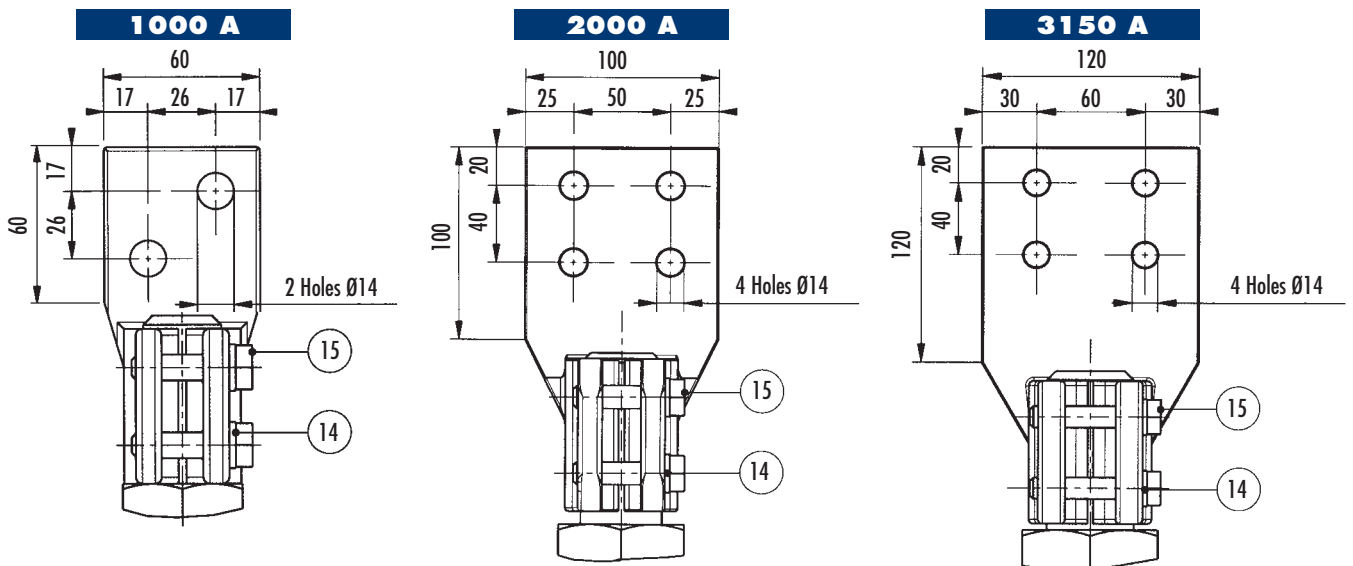

B VIEW

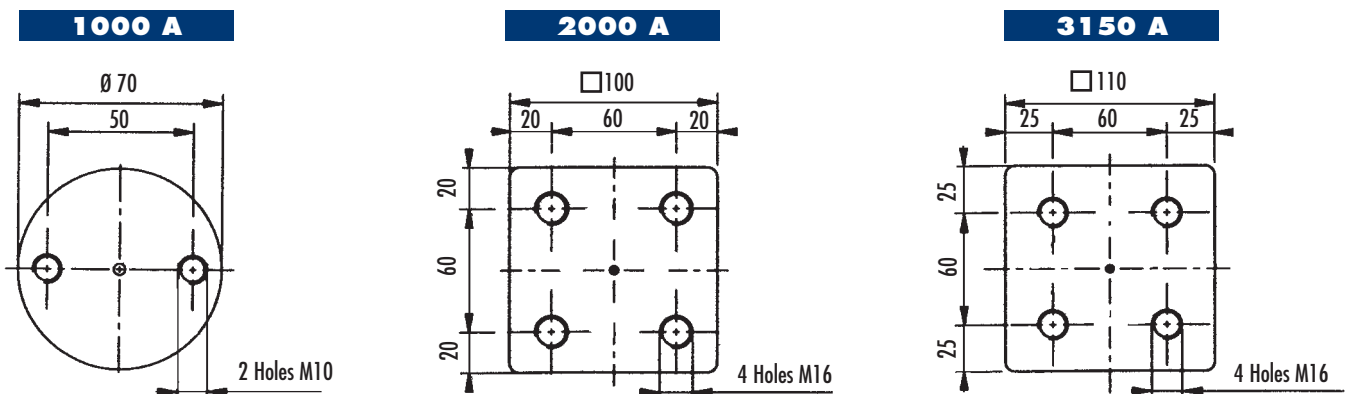

250 A Solution "A"

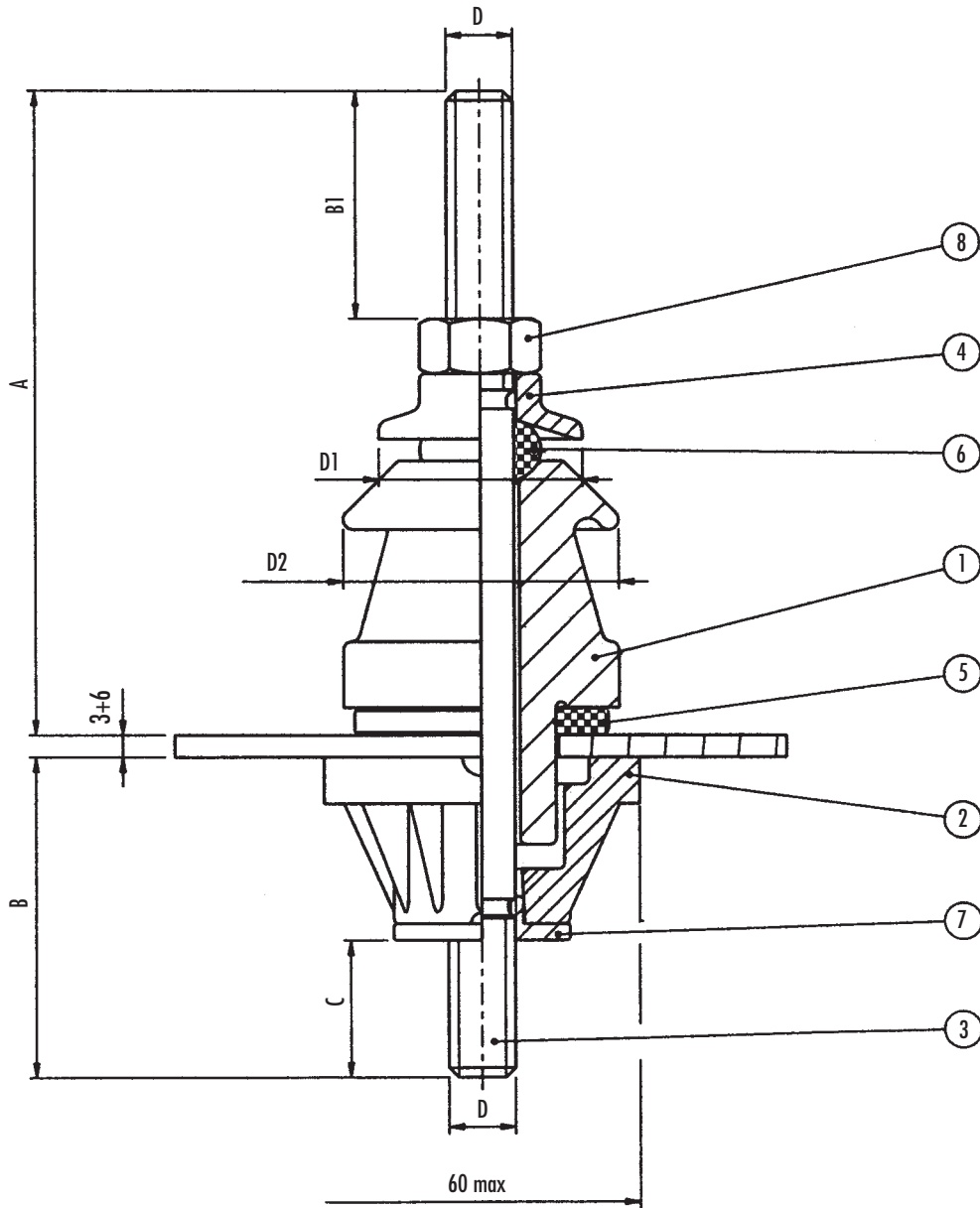

TYPE	A	B(Max)	B1(Min)	C	D	D1	D2(Max)	Tank Hole	Weight
1 kV/250 A	~118	58	40	25	M12	Ø 37	Ø 56	Ø 28	0.42 kg

250 A Solution "A"

ITEM	DESCRIPTION	Q.TY
1	CERAMIC BODY	1
2	INSULATION BODY	1
3	BOLT	1
4	UPPER WASHER	1
5	GASKET	1
6	GASKET	1
7	LOWER WASHER	1
8	FULL NUT	1

IDENTIFICATION			VOLTAGE TIGHTNESS					
ACCORDING TO STANDARD	RATED VOLTAGE (kV)	RATED CURRENT (A)	LIGHTING IMPULSE (kV)	POWER FREQUENCY (kV)		CREEPAGE DISTANCE MIN. (mm)	ARCING DISTANCE MIN. (mm)	LEE PROTECTED LINE MIN. (mm)
				DRY	WET			
EN 50386	1	250	20	10	10	55	-	-

250 A Solution "B"

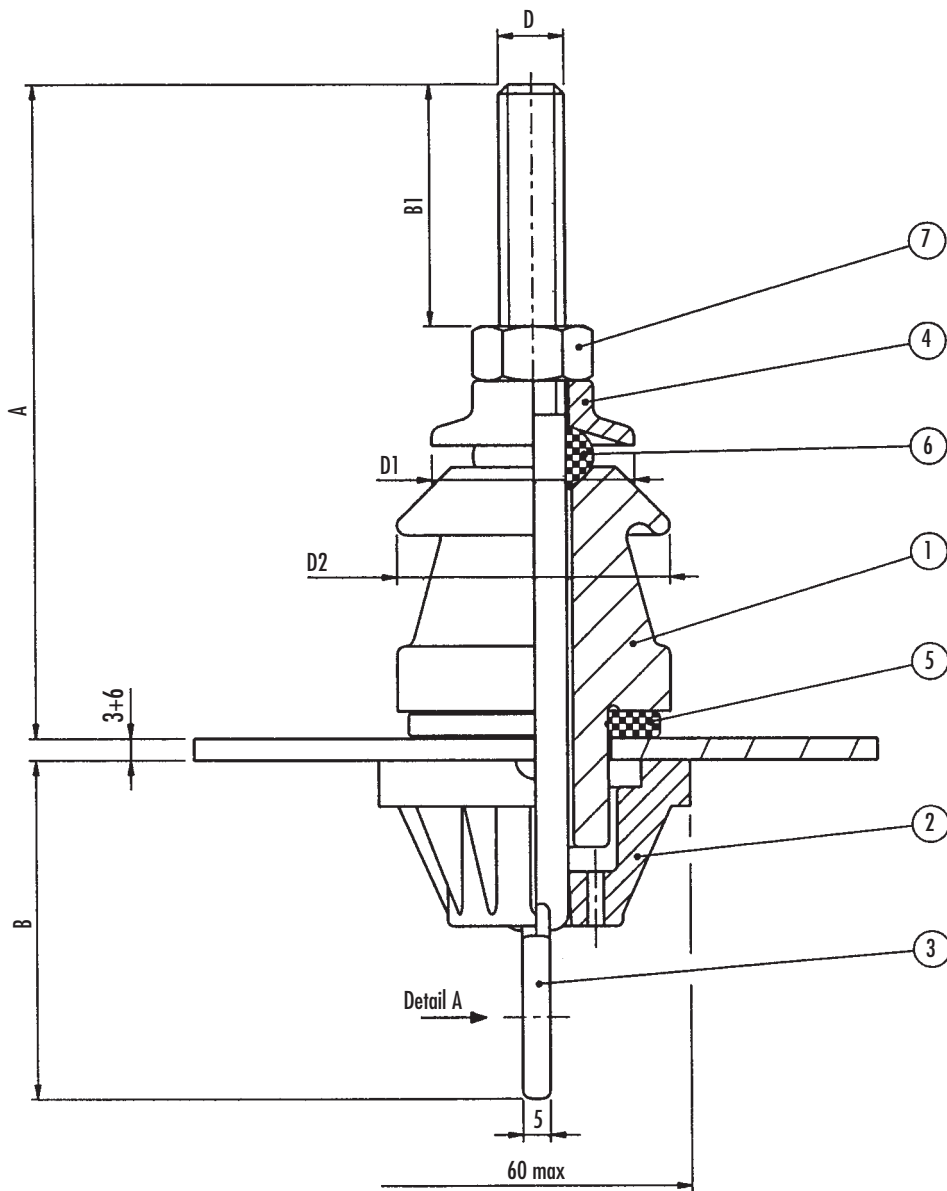

TYPE	A	B(Max)	B1(Min)	D	D1	D2(Max)	Tank Hole	Weight
1 kV/250 A	~121	62	40	M12	Ø 37	Ø 56	Ø 28	0.43 kg

250 A Solution "B"

ITEM	DESCRIPTION	Q.TY
1	CERAMIC BODY	1
2	INSULATION BODY	1
3	BOLT "AP" TYPE	1
4	UPPER WASHER	1
5	GASKET	1
6	GASKET	1
7	FULL NUT	1

IDENTIFICATION			VOLTAGE TIGHTNESS					
ACCORDING TO STANDARD	RATED VOLTAGE (kV)	RATED CURRENT (A)	LIGHTING IMPULSE (kV)	POWER FREQUENCY (kV)		CREEPAGE DISTANCE MIN. (mm)	ARCING DISTANCE MIN. (mm)	LEE PROTECTED LINE MIN. (mm)
				DRY	WET			
EN 50386	1	250	20	10	10	55	-	-

DETAIL A

1250 A

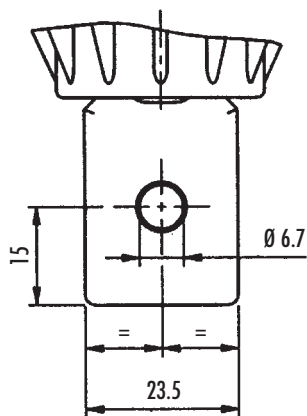

630 A Solution "A"

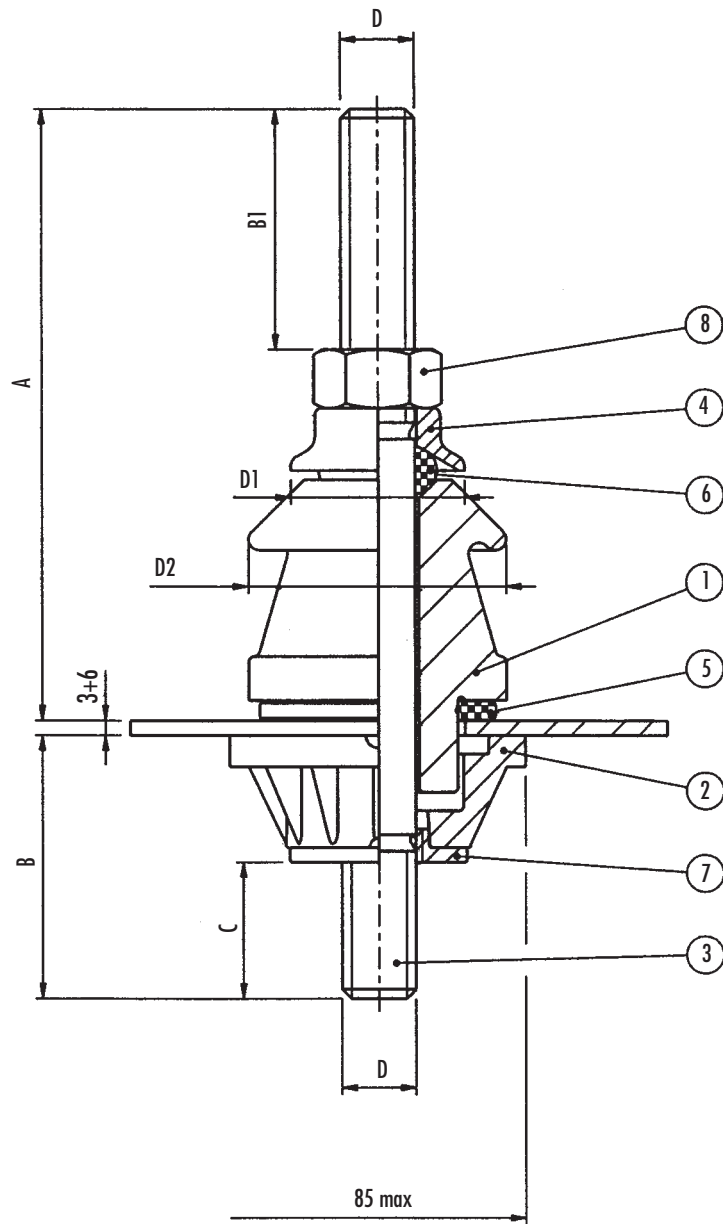

TYPE	A	B(Max)	B1(Min)	C	D	D1	D2(Max)	Tank Hole	Weight
1 kV/630 A	~167	71	65	37	M20	Ø 47	Ø 70	Ø 45	1.22 kg

630 A Solution "A"

ITEM	DESCRIPTION	Q.TY
1	CERAMIC BODY	1
2	INSULATION BODY	1
3	BOLT	1
4	UPPER WASHER	1
5	GASKET	1
6	GASKET	1
7	LOWER WASHER	1
8	FULL NUT	1

IDENTIFICATION			VOLTAGE TIGHTNESS					
ACCORDING TO STANDARD	RATED VOLTAGE (kV)	RATED CURRENT (A)	LIGHTING IMPULSE (kV)	POWER FREQUENCY (kV)		CREEPAGE DISTANCE MIN. (mm)	ARCING DISTANCE MIN. (mm)	LEE PROTECTED LINE MIN. (mm)
				DRY	WET			
EN 50386	1	630	20	10	10	70	-	-

630 A Solution "B"

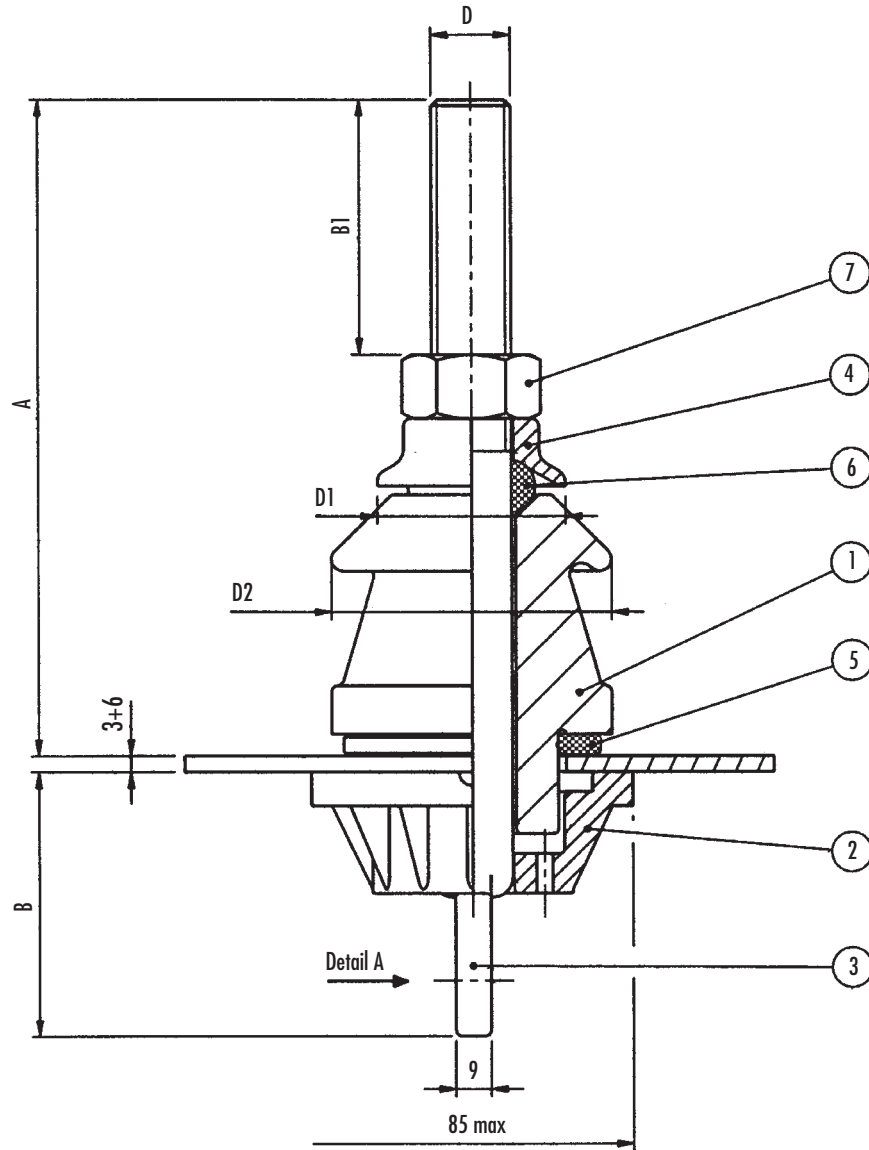

TYPE	A	B(Max)	B1(Min)	D	D1	D2(Max)	Tank Hole	Weight
1 kV/630 A	~165	66	65	M20	Ø 47	Ø 70	Ø 45	1.16 kg

630 A Solution "B"

ITEM	DESCRIPTION	Q.TY
1	CERAMIC BODY	1
2	INSULATION BODY	1
3	BOLT "AP" TYPE	1
4	UPPER WASHER	1
5	GASKET	1
6	GASKET	1
7	FULL NUT	1

IDENTIFICATION			VOLTAGE TIGHTNESS					
ACCORDING TO STANDARD	RATED VOLTAGE (kV)	RATED CURRENT (A)	LIGHTING IMPULSE (kV)	POWER FREQUENCY (kV)		CREEPAGE DISTANCE MIN. (mm)	ARCING DISTANCE MIN. (mm)	LEE PROTECTED LINE MIN. (mm)
				DRY	WET			
EN 50386	1	630	20	10	10	70	-	-

DETAIL A

630 A

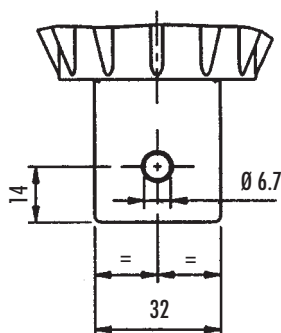

1250 A Solution "A"

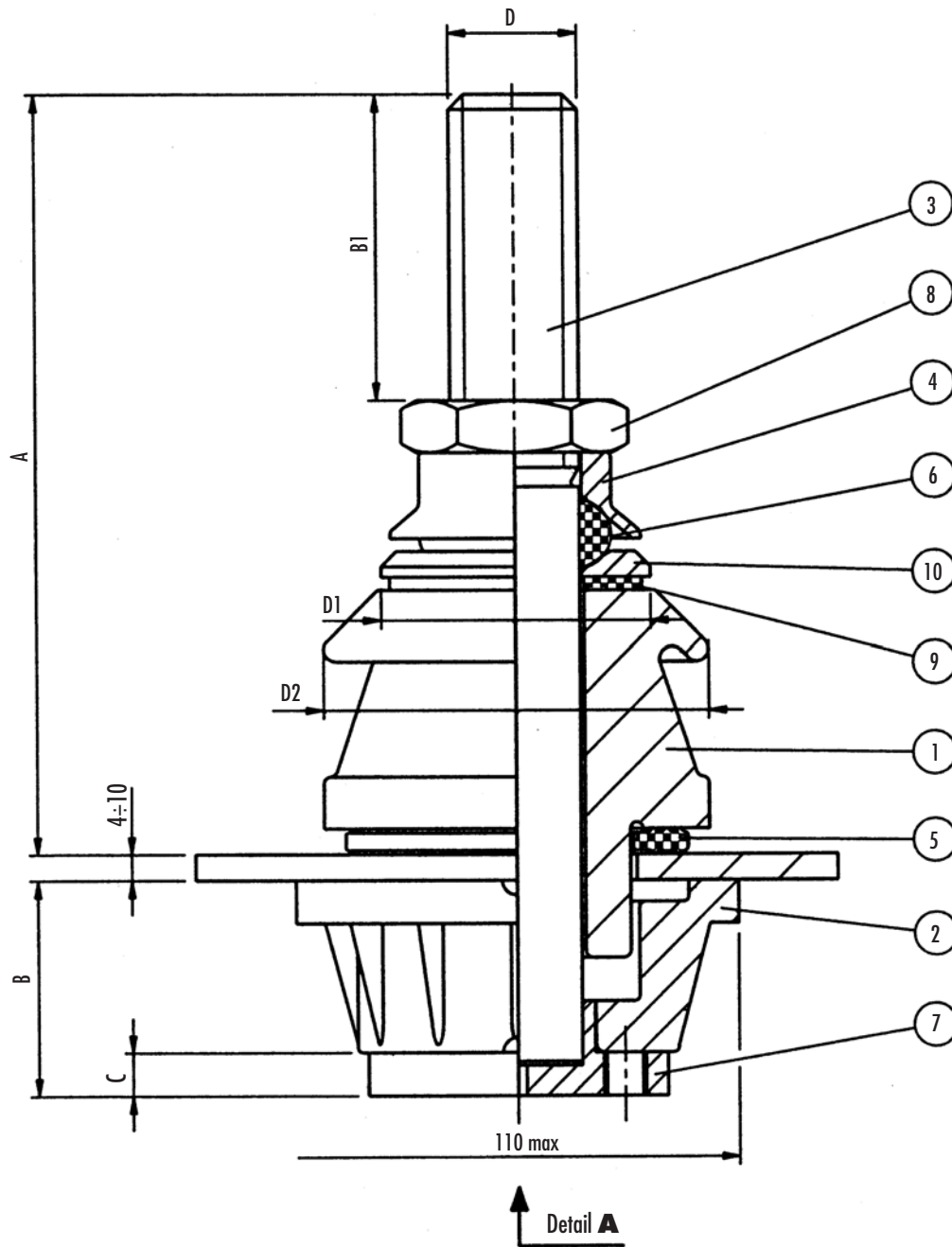

TYPE	A	B(Max)	B1(Min)	C	D	D1	D2(Max)	Tank Hole	Weight
1 kV/1250 A	~176	50	70	10	M30x2	Ø 63	Ø 90	Ø 56	2.81 kg

1250 A Solution "A"

ITEM	DESCRIPTION	Q.TY
1	CERAMIC BODY	1
2	INSULATION BODY	1
3	BOLT	1
4	UPPER WASHER	1
5	GASKET	1
6	GASKET	1
7	LOWER WASHER	1
8	HALF NUT	1
9	GASKET	1
10	MIDDLE WASHER	1

IDENTIFICATION			VOLTAGE TIGHTNESS					
ACCORDING TO STANDARD	RATED VOLTAGE (kV)	RATED CURRENT (A)	LIGHTING IMPULSE (kV)	POWER FREQUENCY (kV)		CREEPAGE DISTANCE MIN. (mm)	ARCING DISTANCE MIN. (mm)	LEE PROTECTED LINE MIN. (mm)
				DRY	WET			
EN 50386	1	1250	20	10	10	75	-	-

DETAIL A

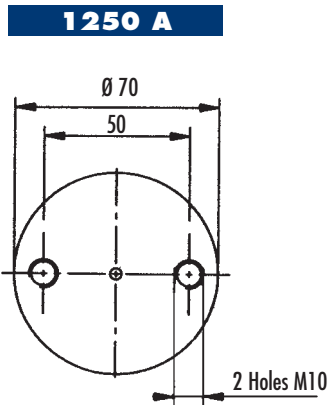

1000 A ÷ 1250 A Solution "B"

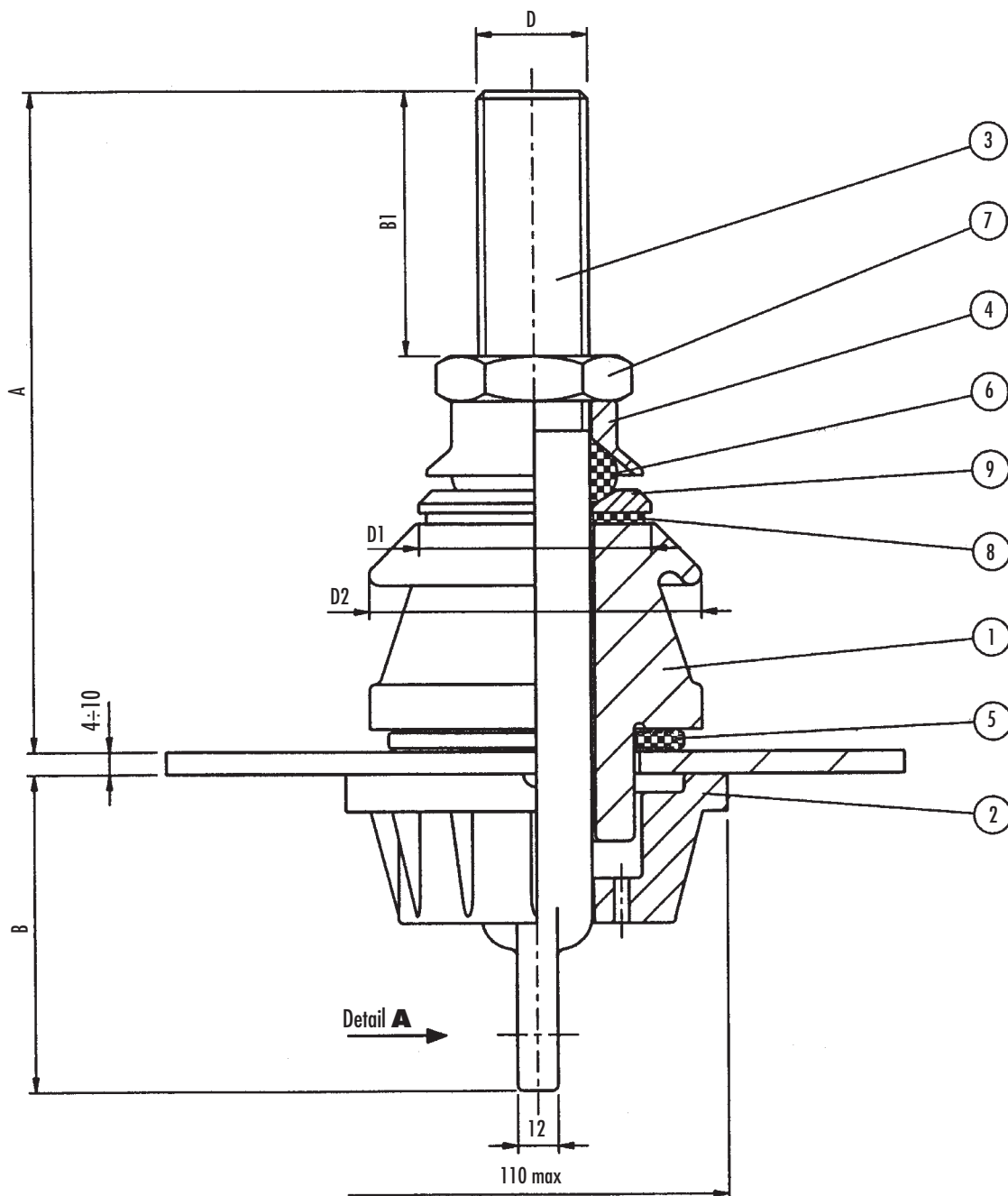

TYPE	POS. 3 (MATERIAL)	A	B(Max)	B1(Min)	D	D1	D2(Max)	Tank Hole	Weight
1 kV/1000 A	BRASS	177	85	70	M30x2	Ø 63	Ø 90	Ø 56	2.67 kg
1 kV/1250 A	COPPER	177	85	70	M30x2	Ø 63	Ø 90	Ø 56	2.73 kg

1000 A ÷ 1250 A Solution "B"

ITEM	DESCRIPTION	Q.TY
1	CERAMIC BODY	1
2	INSULATION BODY	1
3	BOLT "AP" TYPE	1
4	UPPER WASHER	1
5	GASKET	1
6	GASKET	1
7	HALF NUT	1
8	GASKET	1
9	MIDDLE WASHER	1

IDENTIFICATION			VOLTAGE TIGHTNESS					
ACCORDING TO STANDARD	RATED VOLTAGE (kV)	RATED CURRENT (A)	LIGHTING IMPULSE (kV)	POWER FREQUENCY (kV)		CREEPAGE DISTANCE MIN. (mm)	ARCING DISTANCE MIN. (mm)	LEE PROTECTED LINE MIN. (mm)
				DRY	WET			
EN 50386	1	1000	20	10	10	75	-	-
EN 50386	1	1250	20	10	10	75	-	-

DETAIL A

1000 A ÷ 1250 A

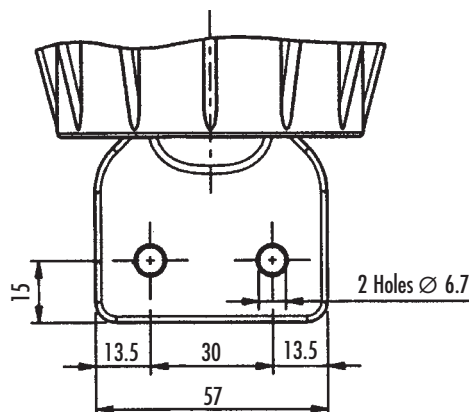

2000 A ÷ 5000 A

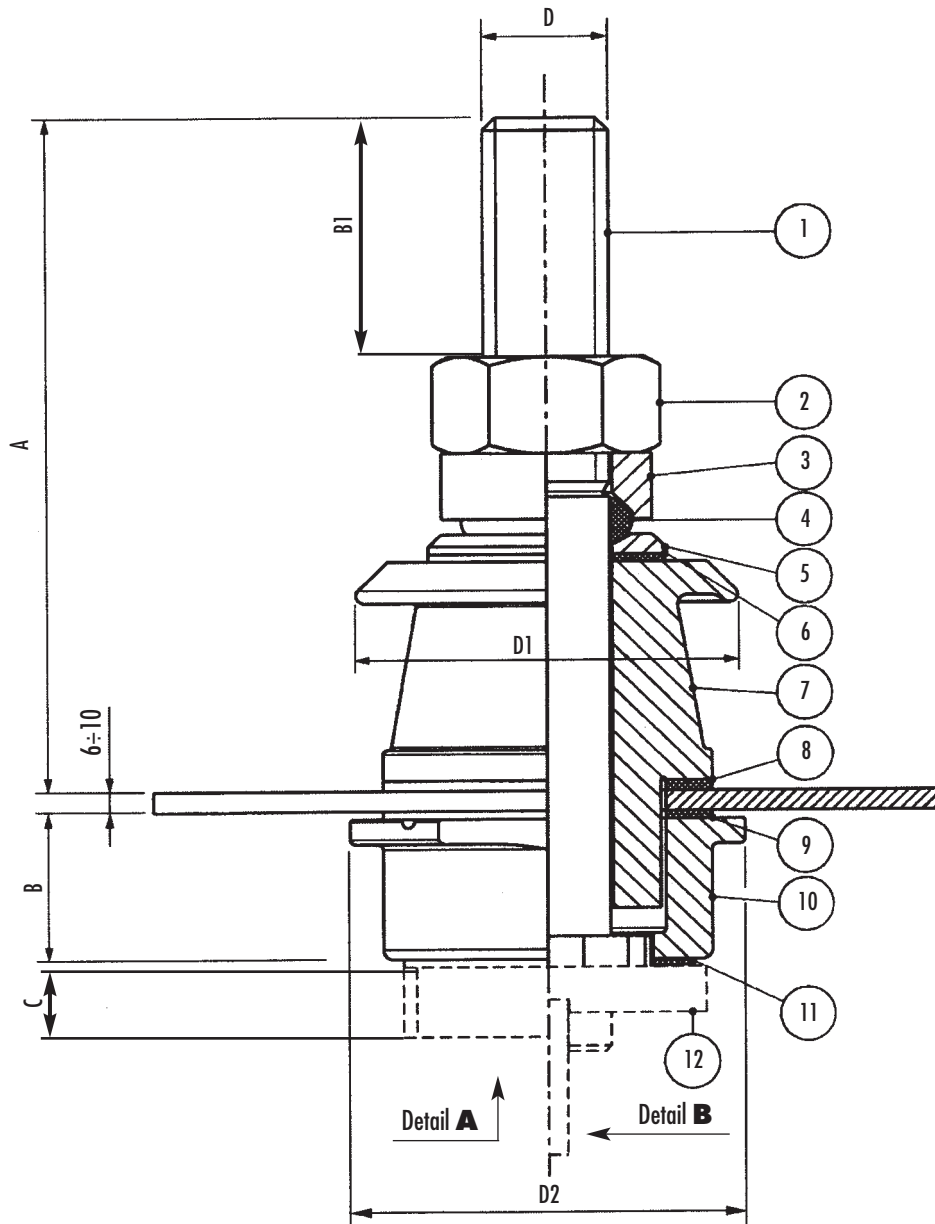

TYPE	A	B(Min)	B1(Min)	C	D	D1(Max)	D2(Max)	Tank Hole	Weight
1 kV/2000 A	~ 240	35	90	15	M42x3	Ø 104	Ø 125	Ø 70	6.24 kg
1 kV/3150 A	~ 250	35	90	15	M48x3	Ø 125	Ø 150	Ø 90	8.45 kg
1 kV/4000 A	~ 300	40	110	24	M55x3	Ø 180	Ø 180	Ø 118	16.60 kg
1 kV/5000 A	~ 310	40	110	24	M64x3 or Ø58	Ø 180	Ø 180	Ø 118	18.95 kg

2000 A ÷ 5000 A

ITEM	DESCRIPTION	Q.TY
1	BOLT	1
2	HALF NUT	1
3	UPPER WASHER	1
4	GASKET	1
5	MIDDLE WASHER	1
6	GASKET	1
7	CERAMIC BODY	1
8	GASKET	1
9	GASKET	1
10	INSULATION BODY*	1
11	GASKET	1
12	LOWER WASHER	1

*IF POLIMERIC ITEMS 9 AND 11 ARE NOT SUPPLIED.

IDENTIFICATION			VOLTAGE TIGHTNESS					
ACCORDING TO STANDARD	RATED VOLTAGE (kV)	RATED CURRENT (A)	LIGHTING IMPULSE (kV)	POWER FREQUENCY (kV)		CREEPAGE DISTANCE MIN. (mm)	ARCING DISTANCE MIN. (mm)	LEE PROTECTED LINE MIN. (mm)
				DRY	WET			
EN 50386	1	2000	20	10	10	75	—	—
EN 50386	1	3150	20	10	10	75	—	—
EN 50386	1	4000	20	10	10	85	—	—
EN 50386	1	5000	20	10	10	85	—	—

DETAIL A

2000 A ÷ 5000 A

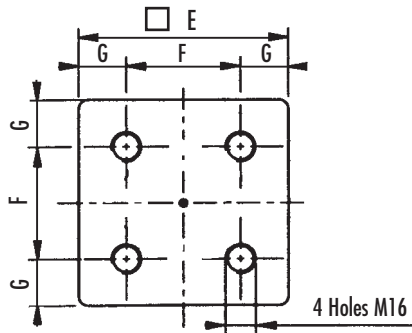

In	E	F	G
2000 A	100	60	20
3150 A	110	60	25
4000 A	160	100	30
5000 A	160	100	30

DETAIL B

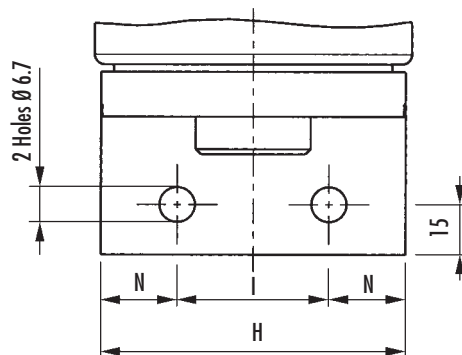

In	H	I	N
2000 A	80	50	15
3150 A	120	60	30

4500 A

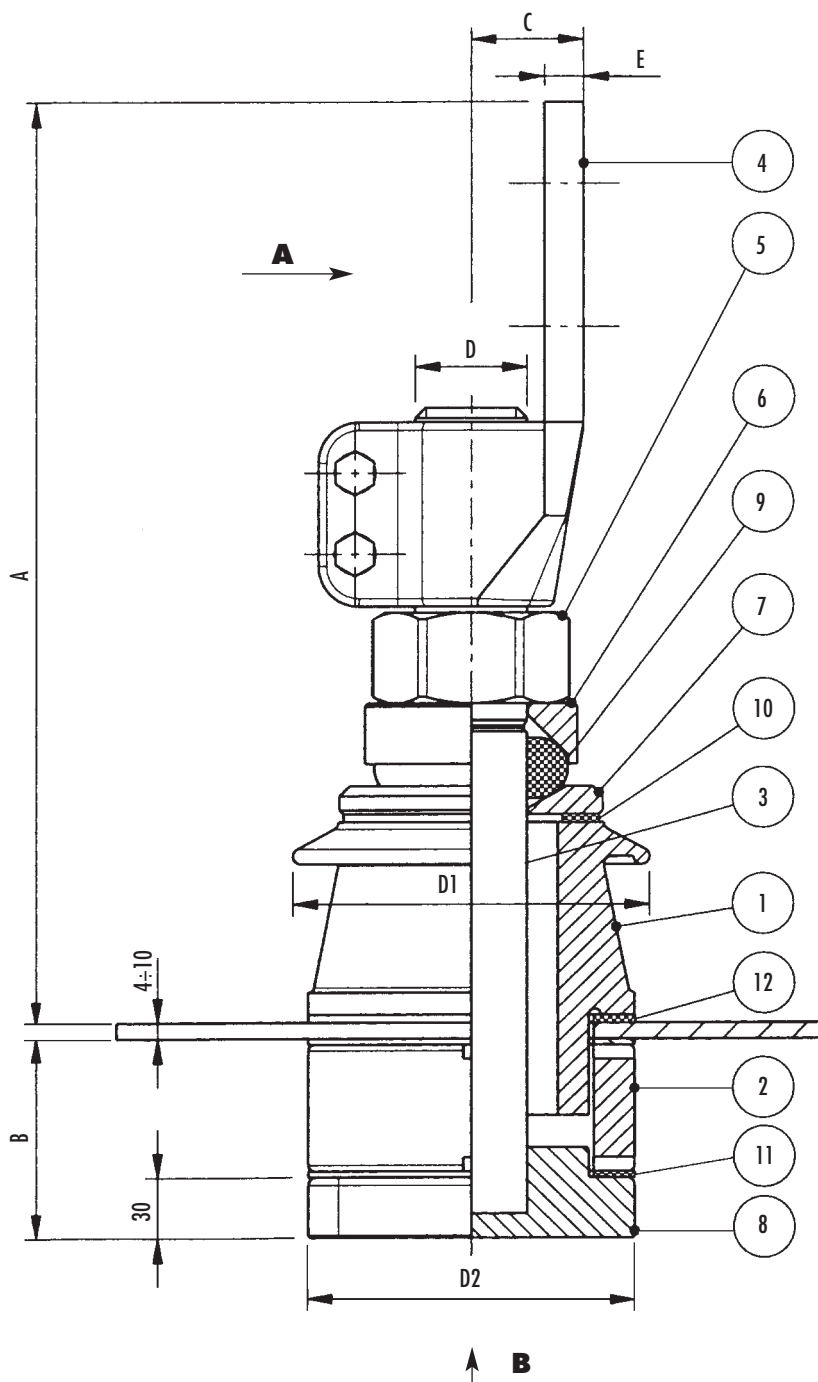

TYPE	A (Max)	B	C	D	D1	D2	E	Tank Hole	Weight
3 kV/4500 A	453	107	55	M55x3	Ø 175	Ø 160	20	Ø 119	29.8 kg

4500 A

ITEM	DESCRIPTION	Q.TY
1	UPPER PORCELAIN	1
2	LOWER PORCELAIN	1
3	BOLT	1
4	FLAG TYPE 4500 A	1
5	FULL NUT	1
6	UPPER WASHER	1
7	MIDDLE WASHER	1
8	LOWER WASHER	1
9	GASKET	1
10	GASKET	1
11	GASKET	2
12	GASKET	1
13	WASHER DIN 125 A	2
14	SCREW DIN 933	2

IDENTIFICATION			VOLTAGE TIGHTNESS					
COMEM DESIGN	RATED VOLTAGE (kV)	RATED CURRENT (A)	LIGHTING IMPULSE (kV)	POWER FREQUENCY (kV)		CREEPAGE DISTANCE MIN. (mm)	ARCING DISTANCE MIN. (mm)	LEE PROTECTED LINE MIN. (mm)
				DRY	WET			
3/4500	3	4500	40	14	10	140	107	20

A VIEW

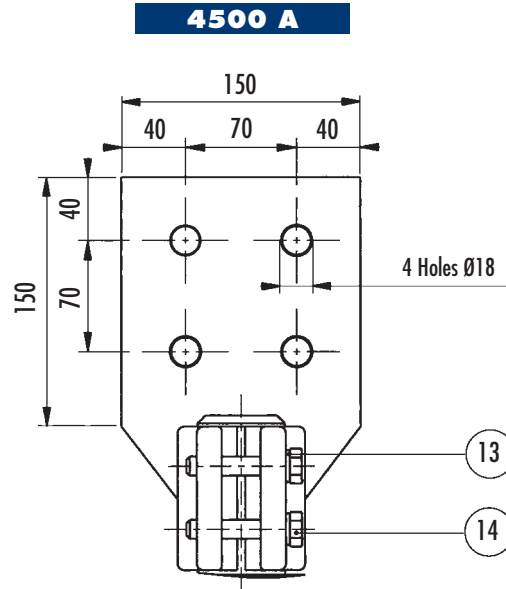

B VIEW

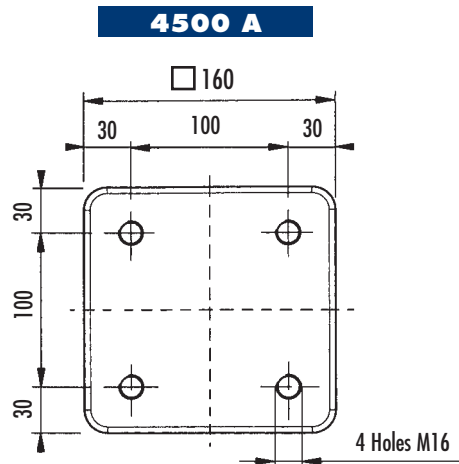

6500 A

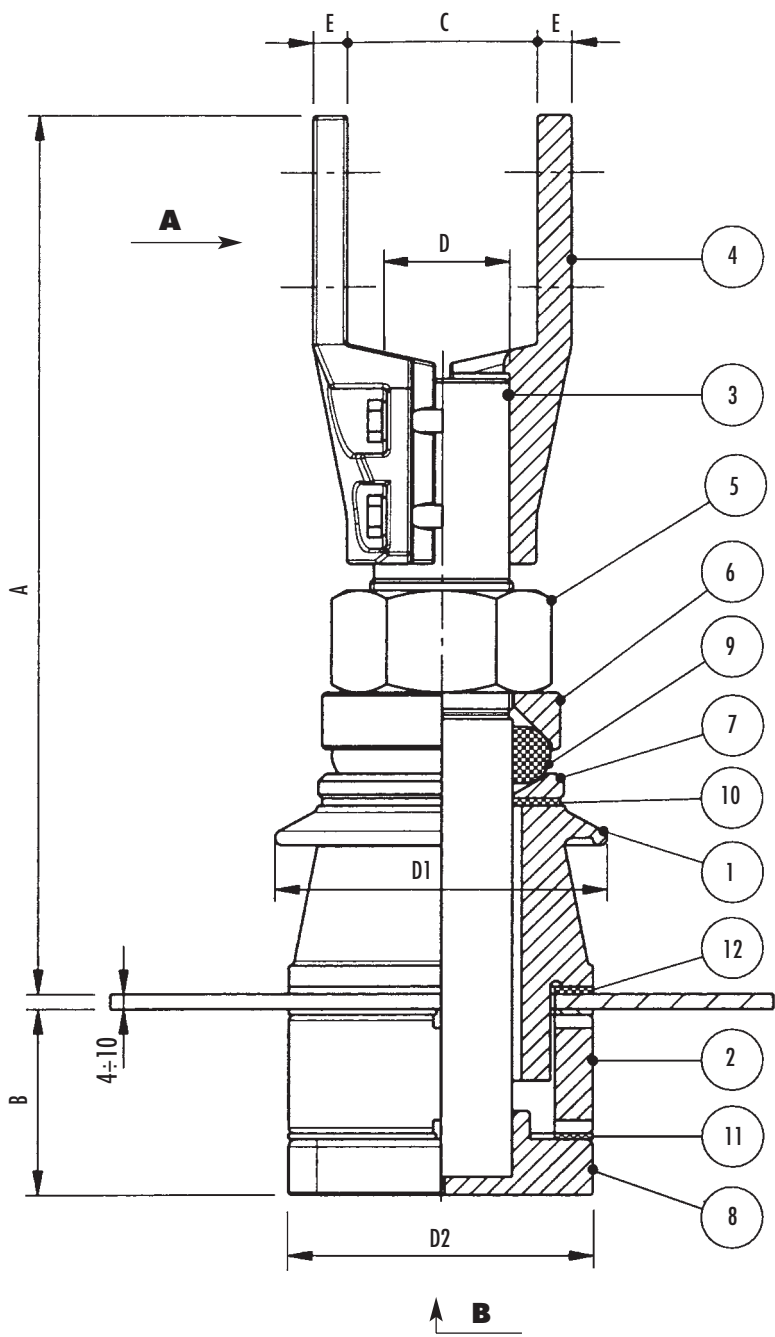

TYPE	A (Max)	B	C	D	D1	D2	E	Tank Hole	Weight
3 kV/6500 A	463	98.5	100	Ø 71	Ø 175	Ø 160	18	Ø 119	42 kg

6500 A

ITEM	DESCRIPTION	Q.TY
1	UPPER PORCELAIN	1
2	LOWER PORCELAIN	1
3	BOLT	1
4	SEMIFLAG	2
5	FULL NUT	1
6	UPPER WASHER	1
7	MIDDLE WASHER	1
8	LOWER WASHER	1
9	GASKET	1
10	GASKET	1
11	GASKET	2
12	GASKET	1
13	FULL NUT	4
14	WASHER DIN 125 A	4
15	SCREW DIN 933	4

IDENTIFICATION			VOLTAGE TIGHTNESS			CREEPAGE DISTANCE MIN. (mm)	ARCING DISTANCE MIN. (mm)	LEE PROTECTED LINE MIN. (mm)
COMEM DESIGN	RATED VOLTAGE (kV)	RATED CURRENT (A)	LIGHTING IMPULSE (kV)	POWER FREQUENCY (kV)				
				DRY	WET			
3/6500	3	6500	40	14	10	140	107	20

A VIEW

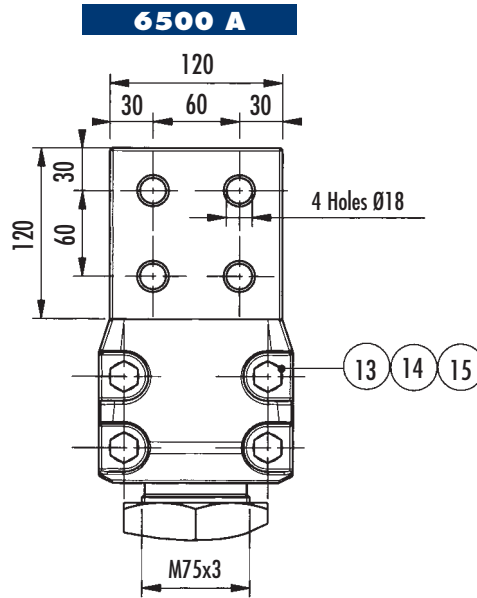

B VIEW

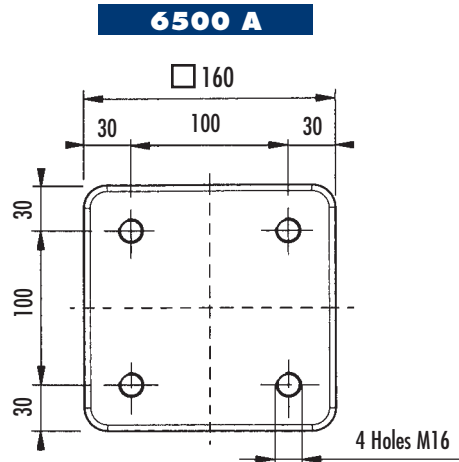

WARNING: Fill out the sheet only if it is different from the specific relevant standard

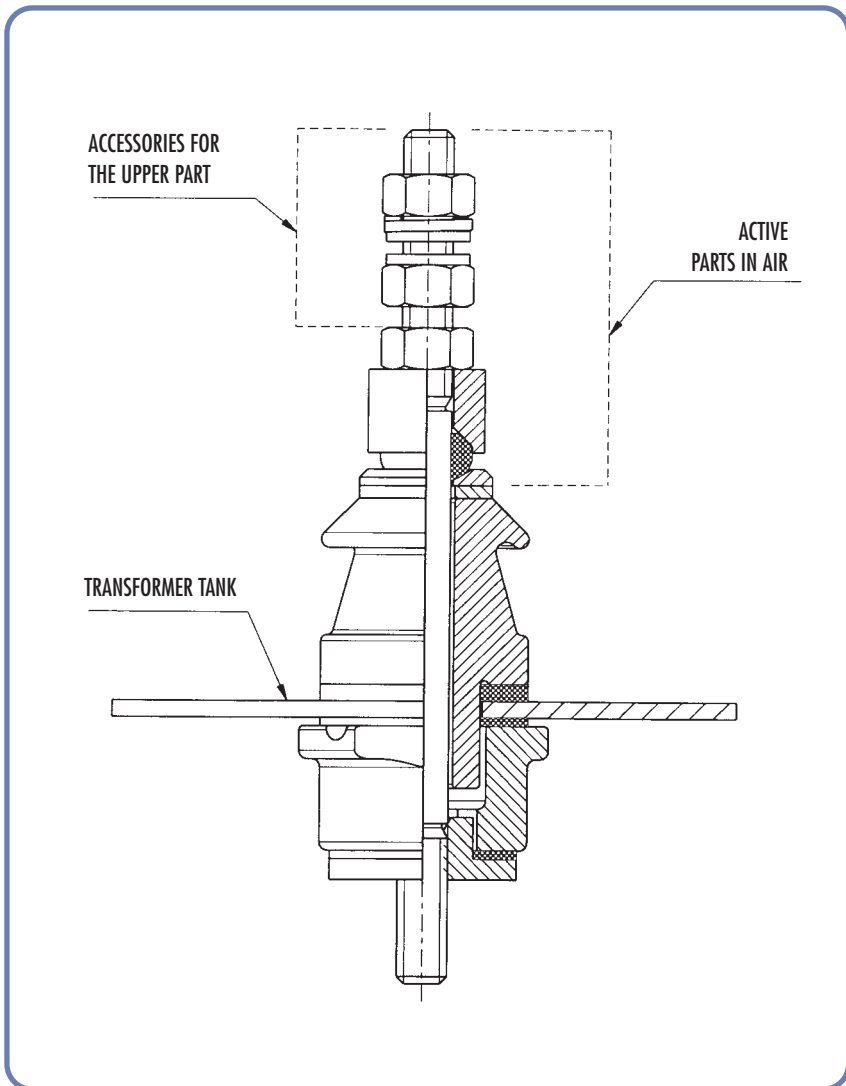

• **VOLTAGE (kV):**

• **CURRENT (A):**

• **RELEVANT STANDARD:**

- DIN
- CENELEC Catalogue page:
- COMEM
- Other:

• **ACTIVE PARTS IN AIR:**

- Tinned 10 µm
- Silver-plated 3 µm
- Other:

• **FIXING COMPONENTS**

- Stainless steel
- Galvanized steel

• **GASKETS:**

- NBR (-25 °C/+115 °C)
- NBR (-40 °C/+115 °C)
- VITON (-10 °C/+150 °C)
- Special types:

• **STRUCTURAL DETAILS ACCORDING TO CUSTOMER SPECIFICATIONS:**

.....

.....

.....

• **ACCESSORIES FOR THE UPPER PART:**

Flag: Type: Customer drawing:

• **Insulators packaged in kits are furnished on request.**

• **NOTES:**

.....

.....

.....

.....



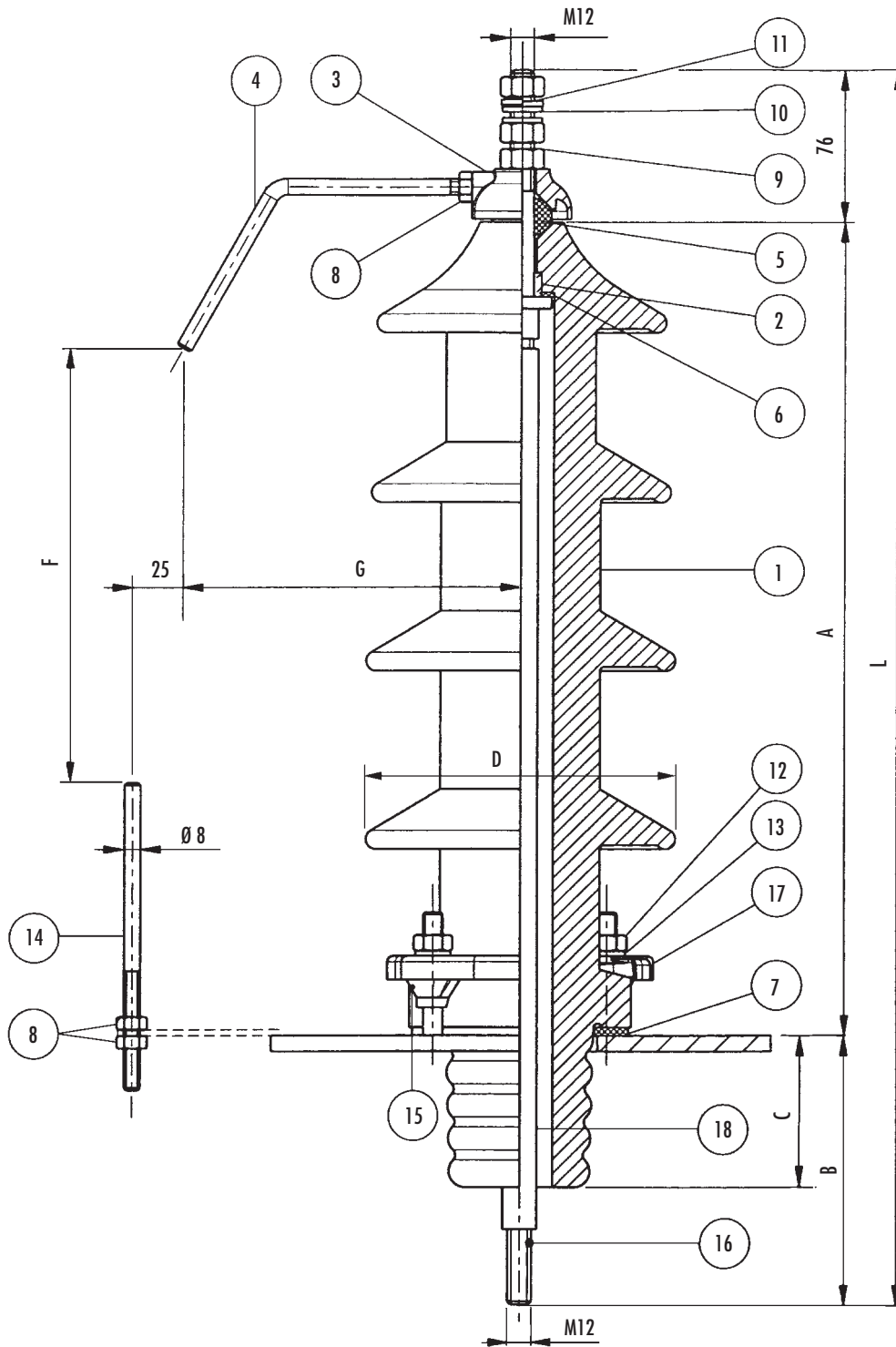

Insulator installation and fastening details: see B15 - Type A or B16 Type A

TYPE	A	B	L	C	D(Max)	F	G	N° of sheds	Tank Hole	Weight
12 kV/250 A	234	120	430	61	Ø 140	85	150	2	Ø 78	4.5 kg
24 kV/250 A	309	135	520	76	Ø 155	155	150	3	Ø 78	6.1 kg
36 kV/250 A	409	135	620	76	Ø 155	220	170	4	Ø 78	7.5 kg

250 A

ITEM	DESCRIPTION	Q.TY
1	PORCELAIN	1
2	UPPER BOLT	1
3	CAP	1
4	UPPER HORN	1
5	GASKET	1
6	GASKET	1
7	GASKET	1
8	FULL NUT	3
9	FULL NUT	3
10	WASHER DIN 125 A	2
11	WASHER DIN 127 B	1
12	FULL NUT	4
13	WASHER DIN 125 A	4
14	LOWER HORN	1
15	PRESSBITS	4
16	LOWER BOLT	1
17	FLANGE	1
18	INSULATING TUBE	1

IDENTIFICATION			VOLTAGE TIGHTNESS			CREEPAGE DISTANCE MIN. (mm)	ARCING DISTANCE MIN. (mm)	LEE PROTECTED LINE MIN. (mm)
ACCORDING TO STANDARD	RATED VOLTAGE (kV)	RATED CURRENT (A)	LIGHTING IMPULSE (kV)	POWER FREQUENCY (kV)				
				DRY	WET			
DIN 42531-68	12	250	75	28	—	305	235	165
DIN 42531-68	24	250	125	50	—	450	310	212
DIN 42531-68	36	250	170	70	—	607	408	288

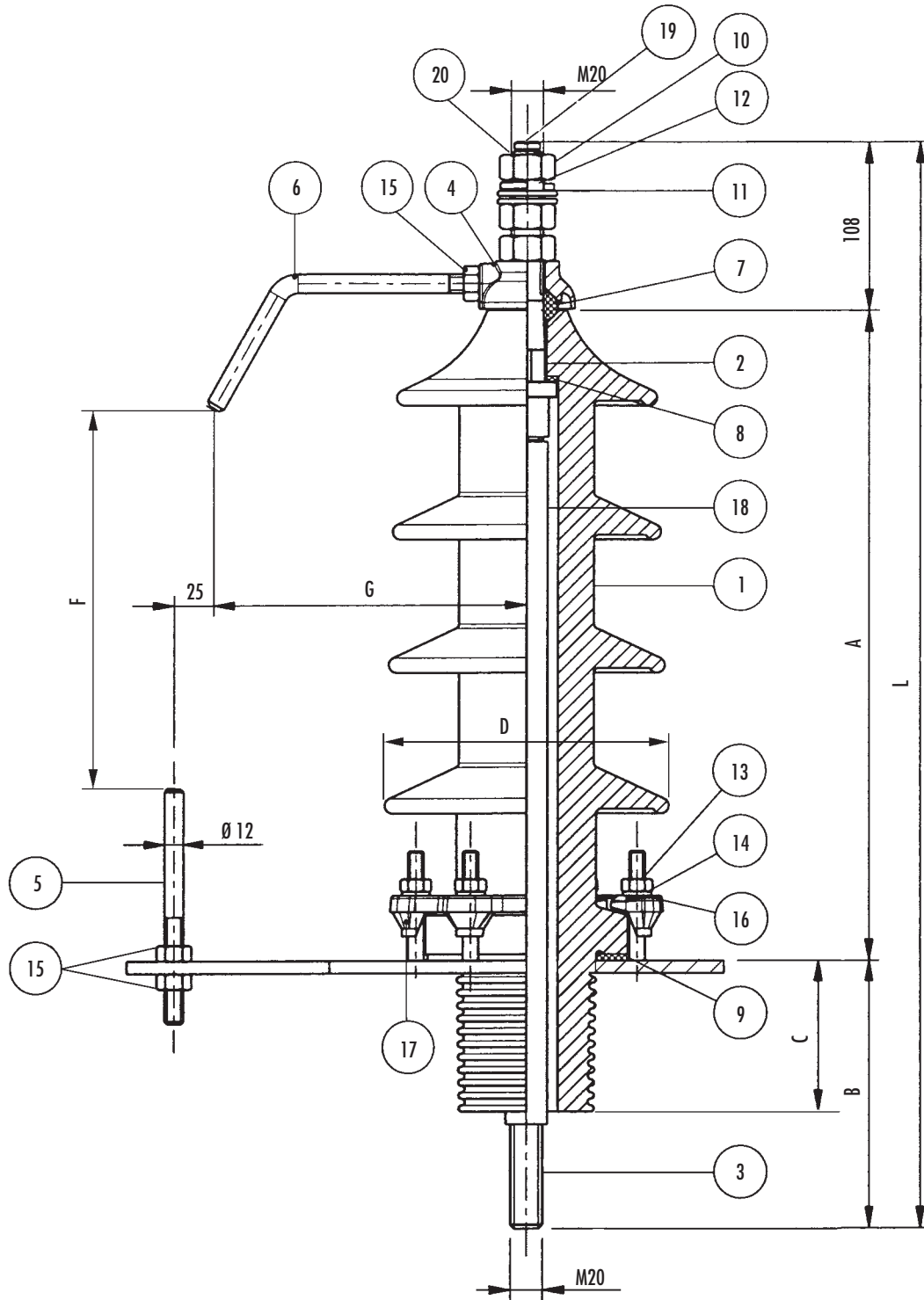

Insulator installation and fastening details: see B15 - Type B

TYPE	A	B	L	C	D(Max)	F	G	N° of sheds	Tank Hole	Weight
12 kV/630 A	234	136	478	61	Ø 150	85	180	2	Ø 90	7.2 kg
24 kV/630 A	309	150	567	76	Ø 165	155	180	3	Ø 90	9.2 kg
36 kV/630 A	414	170	692	96	Ø 180	220	200	4	Ø 90	12.2 kg

630 A

ITEM	DESCRIPTION	Q.TY
1	PORCELAIN	1
2	UPPER BOLT	1
3	LOWER BOLT	1
4	CAP	1
5	LOWER HORN	1
6	UPPER HORN	1
7	GASKET	1
8	GASKET	1
9	GASKET	1
10	FULL NUT	3
11	WASHER DIN 125 A	2
12	WASHER DIN 127 B	1
13	FULL NUT	6
14	WASHER DIN 125 A	6
15	FULL NUT	3
16	FLANGE	1
17	PRESSBITS	6
18	INSULATING TUBE	1
19	VENTING - SCREW	1
20	GASKET FOR VENTING SCREW	1

IDENTIFICATION			VOLTAGE TIGHTNESS			CREEPAGE DISTANCE MIN. (mm)	ARCING DISTANCE MIN. (mm)	LEE PROTECTED LINE MIN. (mm)
ACCORDING TO STANDARD	RATED VOLTAGE (kV)	RATED CURRENT (A)	LIGHTING IMPULSE (kV)	POWER FREQUENCY (kV)				
				DRY	WET			
DIN 42532-69	12	630	75	28	—	305	230	165
DIN 42532-69	24	630	125	50	—	440	315	245
DIN 42532-69	36	630	170	70	—	662	418	332

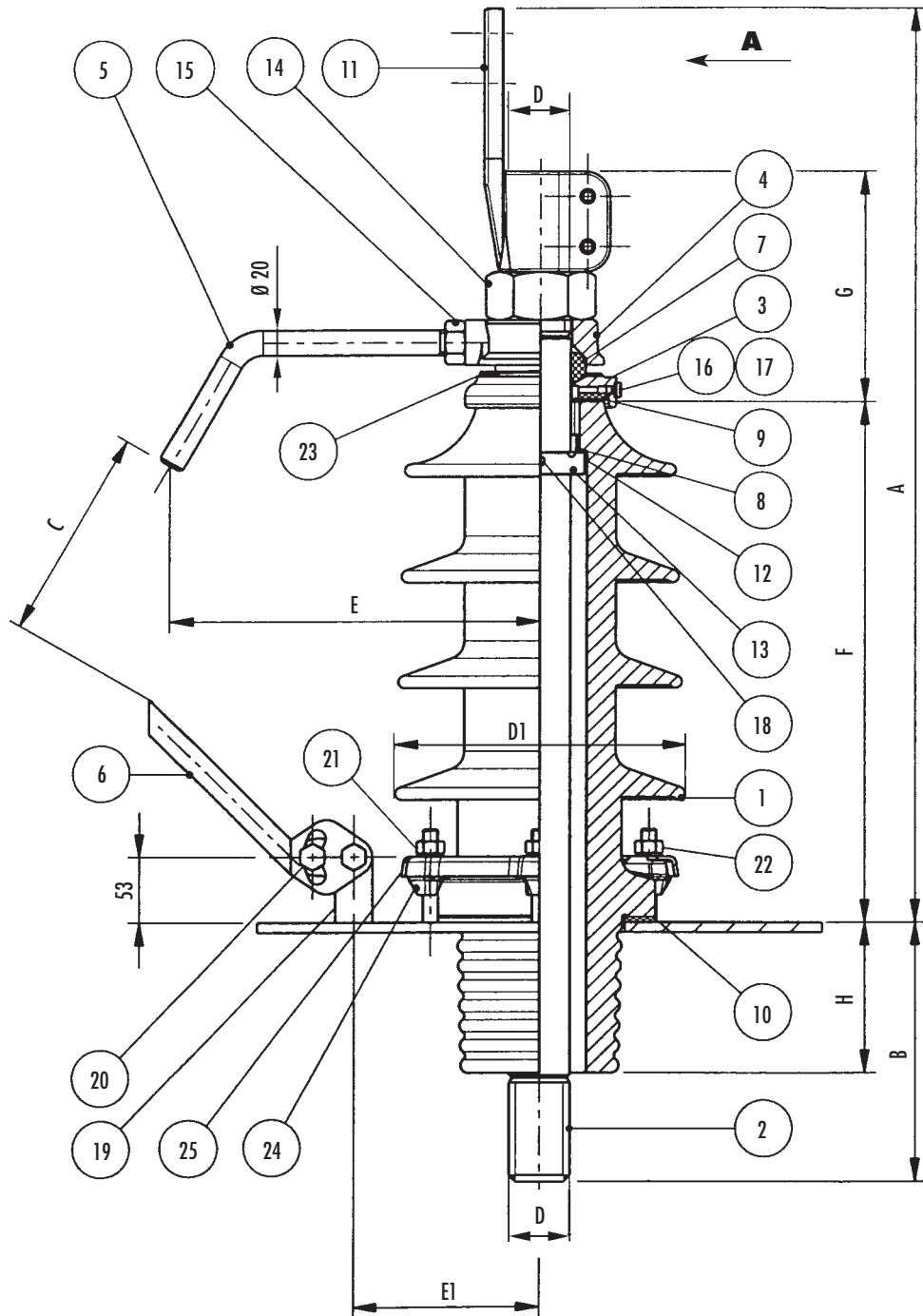

Insulator installation and fastening details: see B15 - Type C for 1000A, type D for 2000A-3150A

TYPE	A	B	C	D	D1-Max	E	E1	F	G	H	N° of sheds	Tank Hole	Weight
12 kV/1000 A	455	158	85	M30x2	Ø 170	225	138	239	148	86	2	Ø 110	15 kg
24 kV/1000 A	530	168	155	M30x2	Ø 185	225	138	314	148	96	3	Ø 110	18 kg
36 kV/1000 A	635	198	220	M30x2	Ø 200	285	138	419	148	121	4	Ø 110	22 kg
12 kV/2000 A	530	158	85	M42x3	Ø 190	230	148	239	178	86	2	Ø 135	23 kg
24 kV/2000 A	605	168	155	M42x3	Ø 210	230	148	314	178	96	3	Ø 135	29 kg
36 kV/2000 A	710	198	220	M42x3	Ø 230	290	148	419	178	121	4	Ø 135	35 kg
12 kV/3150 A	560	168	85	M48x3	Ø 190	235	148	239	183	86	2	Ø 135	28.5 kg
24 kV/3150 A	635	178	155	M48x3	Ø 210	235	148	314	183	96	3	Ø 135	32.5 kg
36 kV/3150 A	740	208	220	M48x3	Ø 230	295	148	419	183	121	4	Ø 135	40 kg

1000 A ÷ 3150 A

ITEM	DESCRIPTION	Q.TY
1	PORCELAIN	1
2	BOLT	1
3	CAP	1
4	WASHER	1
5	UPPER HORN	1
6	LOWER HORN	1
7	GASKET	1
8	GASKET	1
9	GASKET	1
10	GASKET	1
11	FLAG DIN 43675	1
12	PRESSURE RING	1
13	STOP RING	1
14	FULL NUT	1
15	FULL NUT	1
16	AIR SCREW	1
17	GASKET	1
18	SCREW DIN 914	1
19	SUPPORT	1
20	SCREW DIN 933	2
21	WASHER DIN 125 A	8
22	FULL NUT	8
23	CONTACT RING	1
24	PRESSBITS	6
25	FLANGE	1
26	SCREW DIN 933	2

IDENTIFICATION			VOLTAGE TIGHTNESS					
ACCORDING TO STANDARD	RATED VOLTAGE (kV)	RATED CURRENT (A)	LIGHTING IMPULSE (kV)	POWER FREQUENCY (kV)		CREEPAGE DISTANCE MIN. (mm)	ARCING DISTANCE MIN. (mm)	LEE PROTECTED LINE MIN. (mm)
				DRY	WET			
DIN 42533-69	12	1000	75	—	28	295	85	42
DIN 42533-69	24	1000	125	—	50	445	155	90
DIN 42533-69	36	1000	170	—	70	635	220	128
DIN 42533-69	12	2000	75	—	28	295	85	48
DIN 42533-69	24	2000	125	—	50	445	155	90
DIN 42533-69	36	2000	170	—	70	635	220	168
DIN 42533-69	12	3150	75	—	28	295	85	48
DIN 42533-69	24	3150	125	—	50	445	155	90
DIN 42533-69	36	3150	170	—	70	635	220	168

A VIEW

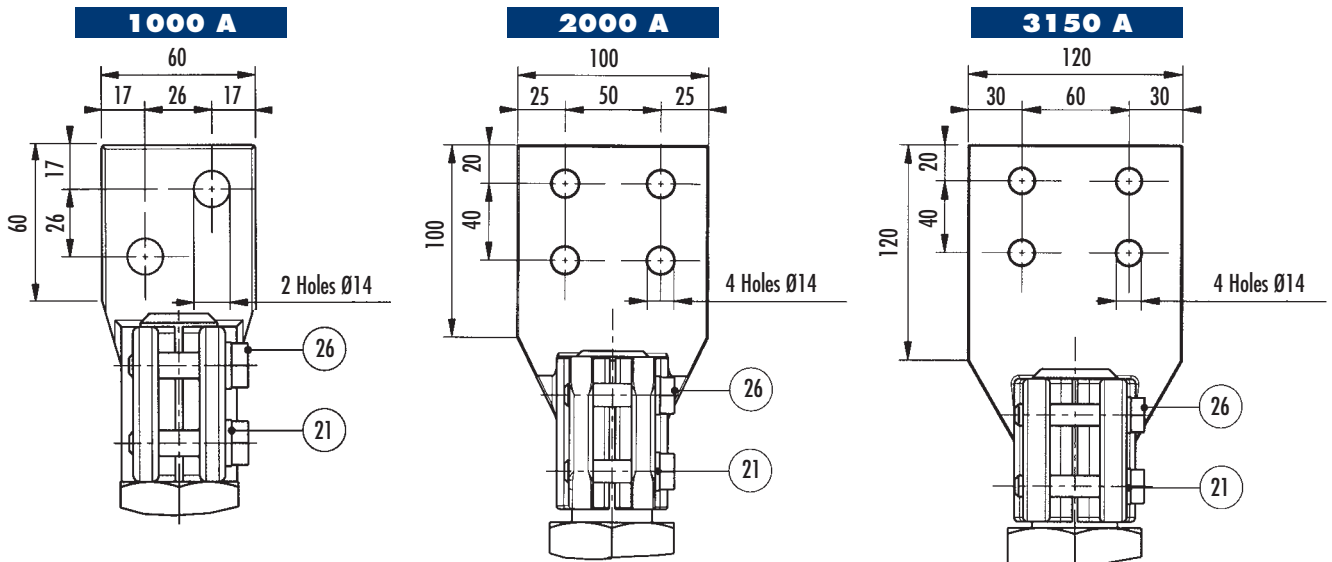

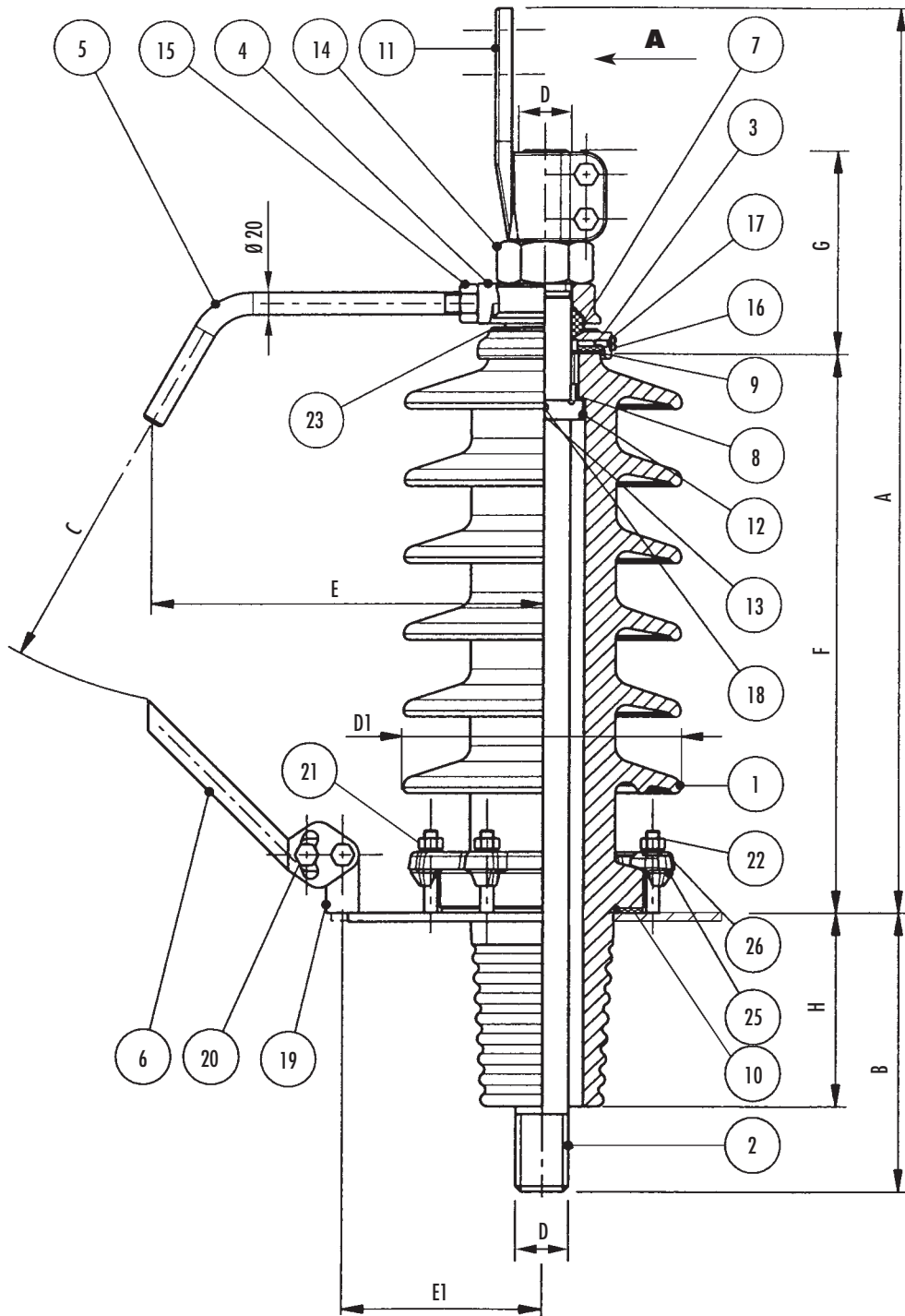

Insulator installation and fastening details: see B15 - Type E

TYPE	A	B	C	D	D1	E	E1	F	G	H	Tank Hole	Weight
52 kV/1000 A	730	253	305	M30x2	∅ 250	350	175	509	148	176	∅ 135	35.2 kg
52 kV/2000 A	807	253	305	M42x3	∅ 250	350	175	509	178	176	∅ 135	44.9 kg
52 kV/3150 A	836	253	305	M48x3	∅ 250	355	180	509	183	176	∅ 135	49.2 kg

1000 A ÷ 3150 A

ITEM	DESCRIPTION	Q.TY
1	PORCELAIN	1
2	BOLT	1
3	CAP	1
4	WASHER	1
5	UPPER HORN	1
6	LOWER HORN	1
7	GASKET	1
8	GASKET	1
9	GASKET	1
10	GASKET	1
11	FLAG DIN 43675	1
12	PRESSURE RING	1
13	STOP RING	1
14	FULL NUT	1
15	FULL NUT	1
16	AIR SCREW	1
17	GASKET	1
18	SCREW DIN 914	2
19	SUPPORT	1
20	SCREW DIN 933	2
21	WASHER DIN 125 A	8
22	FULL NUT	8
23	CONTACT RING	1
24	SCREW DIN 933	2
25	PRESSBITS	6
26	FLANGE	1

IDENTIFICATION			VOLTAGE TIGHTNESS			CREEPAGE DISTANCE MIN. (mm)	ARCING DISTANCE MIN. (mm)	LEE PROTECTED LINE MIN. (mm)
ACCORDING TO STANDARD	RATED VOLTAGE (kV)	RATED CURRENT (A)	LIGHTING IMPULSE (kV)	POWER FREQUENCY (kV)				
				DRY	WET			
DIN 42534-83	52	1000	250	—	95	950	480	340
DIN 42534-83	52	2000	250	—	95	950	480	340
DIN 42534-83	52	3150	250	—	95	950	480	340

A VIEW

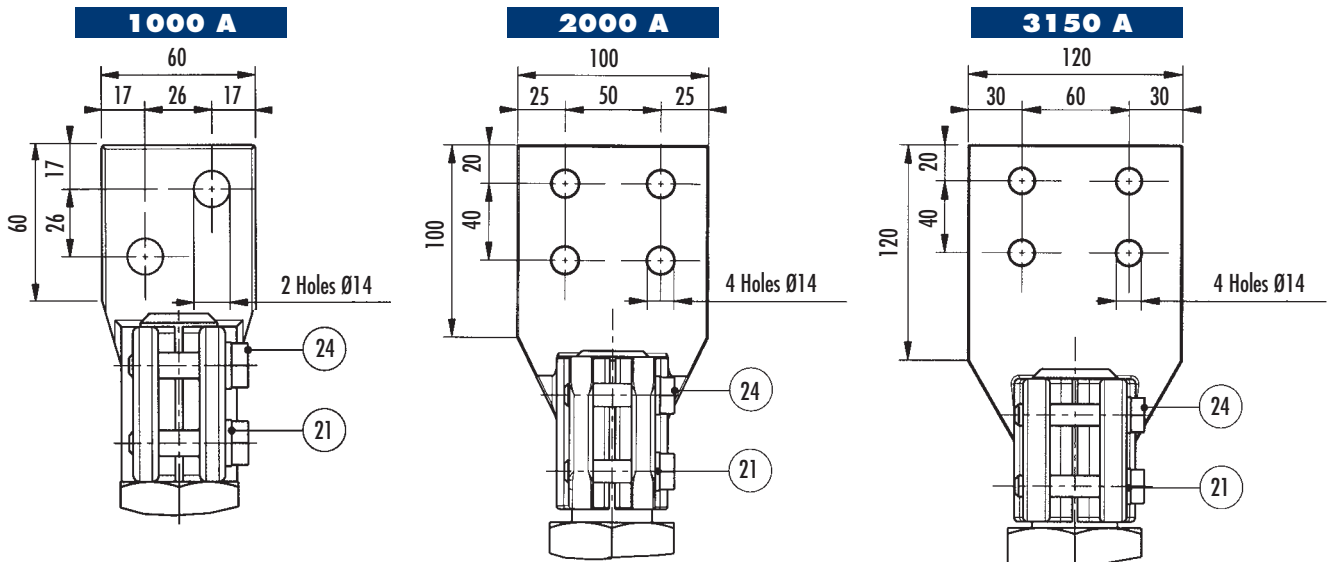

250 A

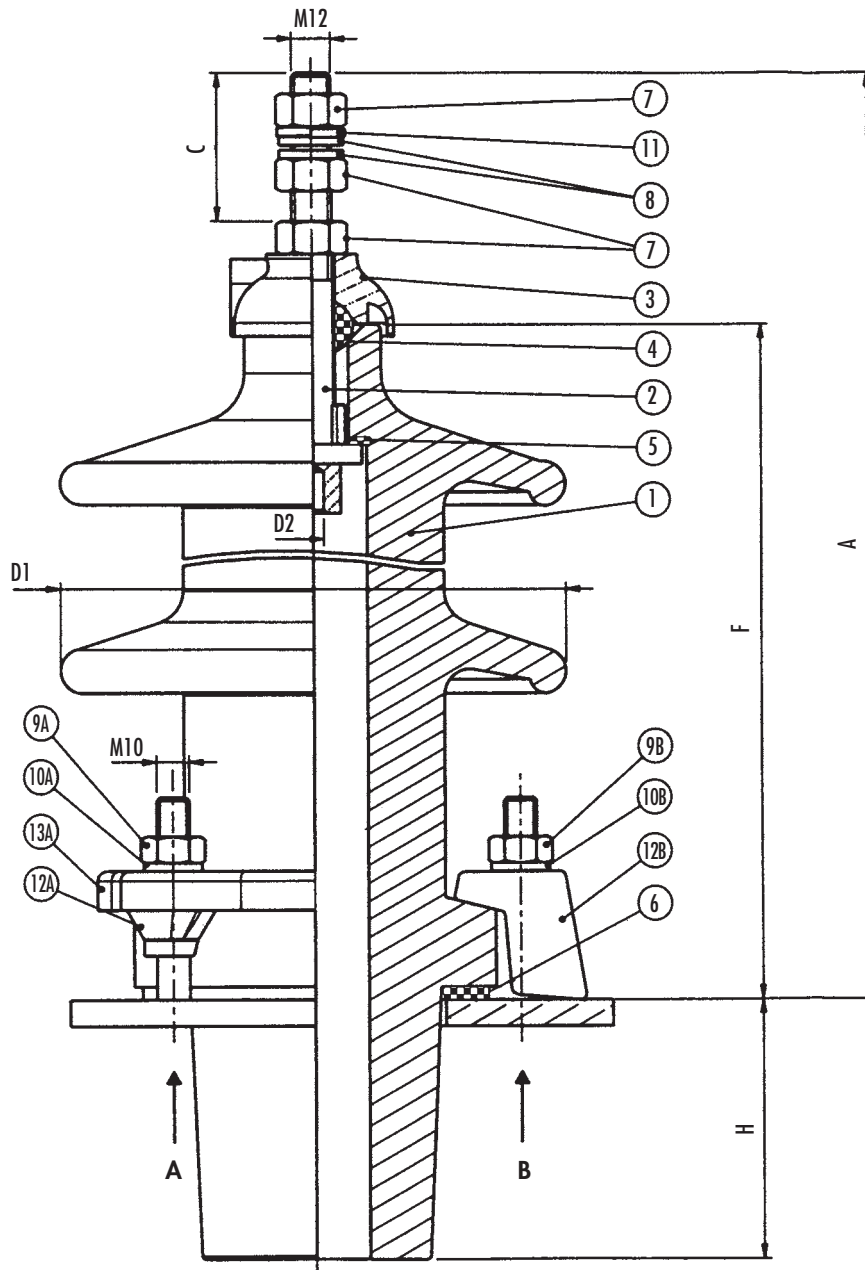

A= Insulator installation and fastening details: see B15 - Type A1 • B= Insulator installation and fastening details: see B16 - Type C

TYPE	A(Max)	C(Min)	F(Max)	H(Max)	D1(Max)	D2(For all)	Insulator Type EN 50180	N° of sheds	Tank Hole	Weight
12 kV/250 A-P1	274	45	194	79	Ø 140		1	2	Ø 80	3.75 kg
12 kV/250 A-P2	274	45	194	79	Ø 140	Ø 4.5	1	2	Ø 80	
12 kV/250 A-P4	388	45	308	79	Ø 150		2	4	Ø 80	5.65 kg
24 kV/250 A-P2	388	45	308	79	Ø 150	OR	2	4	Ø 80	
24 kV/250 A-P3	441	45	361	79	Ø 155	Ø 6	3	5	Ø 80	6.65 kg
36 kV/250 A-P1	441	45	361	79	Ø 155	OR	3	5	Ø 80	
24 kV/250 A-P4	600	45	520	79	Ø 155		4	8	Ø 80	9.35 kg
36 kV/250 A-P3	600	45	520	79	Ø 155	M12	4	8	Ø 80	
36 kV/250 A-P4	600	45	520	79	Ø 190		5	8	Ø 80	12.55 kg

250 A

WITH FIXATION METHOD "A"		
ITEM	DESCRIPTION	Q.TY
1	PORCELAIN	1
2	BOLT	1
3	CAP	1
4	GASKET	1
5	GASKET	1
6	GASKET	1
7	FULL NUT	3
8	WASHER DIN 125 A	2
9 A	FULL NUT	4
10 A	WASHER DIN 125 A	4
11	WASHER	1
12 A	PRESSBITS	4
13 A	FLANGE	1

OR

WITH FIXATION METHOD "B"		
ITEM	DESCRIPTION	Q.TY
1	PORCELAIN	1
2	BOLT	1
3	CAP	1
4	GASKET	1
5	GASKET	1
6	GASKET	1
7	FULL NUT	3
8	WASHER DIN 125 A	2
9B	FULL NUT	3
10B	WASHER DIN 125 A	3
11	WASHER	1
12B	BLOCK	3

IDENTIFICATION			VOLTAGE TIGHTNESS			CREEPAGE DISTANCE MIN. (mm)	ARCING DISTANCE (mm)	POLLUTION LEVEL
ACCORDING TO STANDARD	RATED VOLTAGE (kV)	RATED CURRENT (A)	LIGHTING IMPULSE (kV)	POWER FREQUENCY (kV)				
				DRY	WET			
EN 50180	12	250	75	—	28	192	145	P1
EN 50180	12	250	75	—	28	240	145	P2
EN 50180	12	250	75	—	28	372	260	P4
EN 50180	24	250	125	—	50	480	260	P2
EN 50180	24	250	125	—	50	600	315	P3
EN 50180	24	250	125	—	50	744	465	P4
EN 50180	36	250	170	—	70	576	315	P1
EN 50180	36	250	170	—	70	900	465	P3
EN 50180	36	250	170	—	70	1116	485	P4

630 A

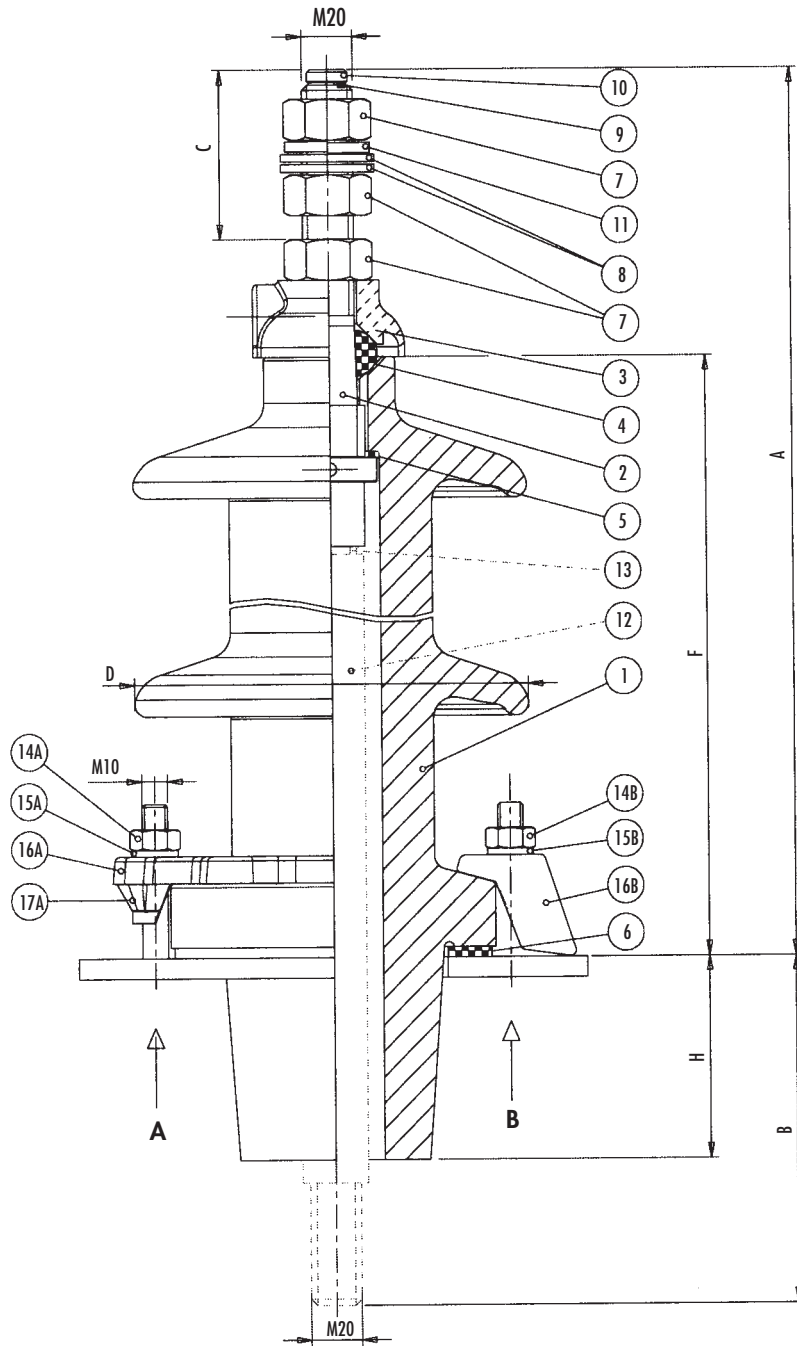

A= Insulator installation and fastening details: see B15 - Type B • B= Insulator installation and fastening details: see B16 - Type B

TYPE	A (MAX)	B (min)	C (min)	F(MAX)	H(MAX)	D(MAX)	Insulator type	N°of sheds	Tank Hole	Weight
12 kV/630 A - P3	354	149	70	239	79	155	6	2	Ø 90	5.4 kg
12 kV/630 A - P4	444	149	70	329	79	170	7	3	Ø 90	7.1 kg
24 kV/630 A - P2	444	149	70	329	79	170	7	3	Ø 90	7.1 kg
24 kV/630 A - P4	544	149	70	427	79	180	8	5	Ø 90	9.8 kg
36 kV/630 A - P2	544	149	70	427	79	180	8	5	Ø 90	9.8 kg
36 kV/630 A - P4	634	149	70	519	79	210	9	7	Ø 90	15.3 kg

630 A

WITH FIXATION METHOD "A"		
ITEM	DESCRIPTION	Q.TY
1	PORCELAIN	1
2	BOLT	1
3	CAP	1
4	GASKET	1
5	GASKET	1
6	GASKET	1
7	FULL NUT	3
8	WASHER DIN 125 A	2
9	GASKET	1
10	AIR SCREW	1
11	WASHER	1
12	INSULATING TUBE (TO BE REQUIRED)	1
13	LOWER BOLT (TO BE REQUIRED)	1
14 A	FULL NUT	6
15 A	WASHER DIN 125 A	6
16 A	FLANGE	1
17 A	PRESSBITS	6

IDENTIFICATION			VOLTAGE TIGHTNESS			CREEPAGE DISTANCE MIN. (mm)	ARCING DISTANCE MIN. (mm)	POLLUTION LEVEL
ACCORDING TO STANDARD	RATED VOLTAGE (kV)	RATED CURRENT (A)	LIGHTING IMPULSE (kV)	POWER FREQUENCY (kV)				
				DRY	WET			
EN-50180	12	630	75	—	28	300	190	P3
EN-50180	12	630	75	—	28	372	285	P4
EN-50180	24	630	125	—	50	480	285	P2
EN-50180	24	630	125	—	50	744	375	P4
EN-50180	36	630	170	—	70	720	375	P2
EN-50180	36	630	170	—	70	1116	475	P4

WITH FIXATION METHOD "B"		
ITEM	DESCRIPTION	Q.TY
1	PORCELAIN	1
2	BOLT	1
3	CAP	1
4	GASKET	1
5	GASKET	1
6	GASKET	1
7	FULL NUT	3
8	WASHER DIN 125 A	2
9	GASKET	1
10	AIR SCREW	1
11	WASHER	1
12	INSULATING TUBE (TO BE REQUIRED)	1
13	LOWER BOLT (TO BE REQUIRED)	1
14 B	FULL NUT	4
15 B	WASHER DIN 125 A	4
16 B	BLOCK	4

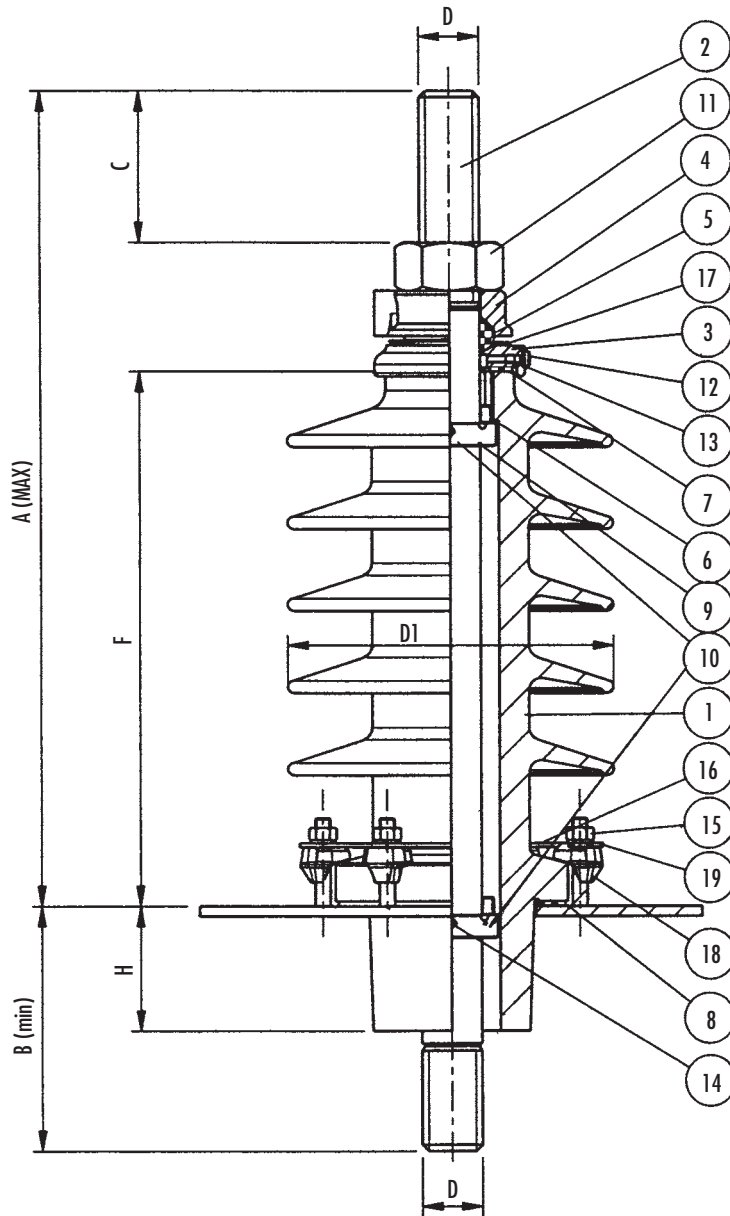

Insulator installation and fastening details: see B15 - Type G for 1250A, type H for 2000A-3150A

TYPE	A (MAX)	B (min)	C (min)	H	D		D1	Insulator type EN 50180	N° of sheds	Tank Hole	Weight
					Thread	Ø H9					
12 kV/1250 A - P4	419	165	80	99	M30x2	NOT AVAILABLE	Ø 210	21	2	Ø 110	12.2 kg
24 kV/1250 A - P3	484	165	80	99	M30x2	NOT AVAILABLE	Ø 210	22	4	Ø 110	13.8 kg
24 kV/1250 A - P4	579	165	80	99	M30x2	NOT AVAILABLE	Ø 240	23	5	Ø 110	15.2 kg
36 kV/1250 A - P3	579	165	80	99	M30x2	NOT AVAILABLE	Ø 240	23	5	Ø 110	15.2 kg
36 kV/1250 A - P4	694	165	80	99	M30x2	NOT AVAILABLE	Ø 240	24	6	Ø 110	16.7 kg
12 kV/2000 A - P4	454	185	100	99	M42x3	Ø 40	Ø 230	25	2	Ø 135	19.2 kg
24 kV/2000 A - P3	519	185	100	99	M42x3	Ø 40	Ø 230	26	4	Ø 135	25.1 kg
24 kV/2000 A - P4	614	185	100	99	M42x3	Ø 40	Ø 260	27	5	Ø 135	30.3 kg
36 kV/2000 A - P3	614	185	100	99	M42x3	Ø 40	Ø 260	27	5	Ø 135	30.3 kg
36 kV/2000 A - P4	729	185	100	99	M42x3	Ø 40	Ø 260	28	6	Ø 135	32.6 kg
12 kV/3150 A - P4	474	185	120	99	M48x3	Ø 50	Ø 230	25	2	Ø 135	22.1 kg
24 kV/3150 A - P3	539	185	120	99	M48x3	Ø 50	Ø 230	26	4	Ø 135	29.1 kg
24 kV/3150 A - P4	634	185	120	99	M48x3	Ø 50	Ø 260	27	5	Ø 135	31.9 kg
36 kV/3150 A - P3	634	185	120	99	M48x3	Ø 50	Ø 260	27	5	Ø 135	31.9 kg
36 kV/3150 A - P4	749	185	120	99	M48x3	Ø 50	Ø 260	28	6	Ø 135	33.8 kg

1250 A ÷ 3150 A

ITEM	DESCRIPTION	Q.TY
1	PORCELAIN	1
2	BOLT	1
3	CAP	1
4	WASHER	1
5	GASKET	1
6	GASKET	1
7	GASKET	1
8	GASKET	1
9	STOP RING	1
10	PRESSURE RING	2
11	FULL NUT	1
12	AIR SCREW	1
13	GASKET	1
14	SCREW DIN 914	4
15	FULL NUT	6
16	FLANGE	1
17	CONTACT RING	1
18	PRESSBITS	6
19	WASHER DIN 125 A	6

IDENTIFICATION			VOLTAGE TIGHTNESS			CREPAGE DISTANCE MIN. (mm)	ARCING DISTANCE MIN. (mm)	POLLUTION LEVEL
ACCORDING TO STANDARD	RATED VOLTAGE (kV)	RATED CURRENT (A)	LIGHTING IMPULSE (kV)	POWER FREQUENCY (kV)				
				DRY	WET			
EN-50180	12	1250	75	—	28	372	215	P4
EN-50180	12	2000	75	—	28	372	210	P4
EN-50180	12	3150	75	—	28	372	210	P4
EN-50180	24	1250	125	—	50	600	280	P3
EN-50180	24	1250	125	—	50	744	385	P4
EN-50180	24	2000	125	—	50	600	275	P3
EN-50180	24	2000	125	—	50	744	385	P4
EN-50180	24	3150	125	—	50	600	275	P3
EN-50180	24	3150	125	—	50	744	385	P4
EN-50180	36	1250	170	—	70	900	385	P3
EN-50180	36	1250	170	—	70	1116	500	P4
EN-50180	36	2000	170	—	70	900	385	P3
EN-50180	36	2000	170	—	70	1116	495	P4
EN-50180	36	3150	170	—	70	900	385	P3
EN-50180	36	3150	170	—	70	1116	495	P4

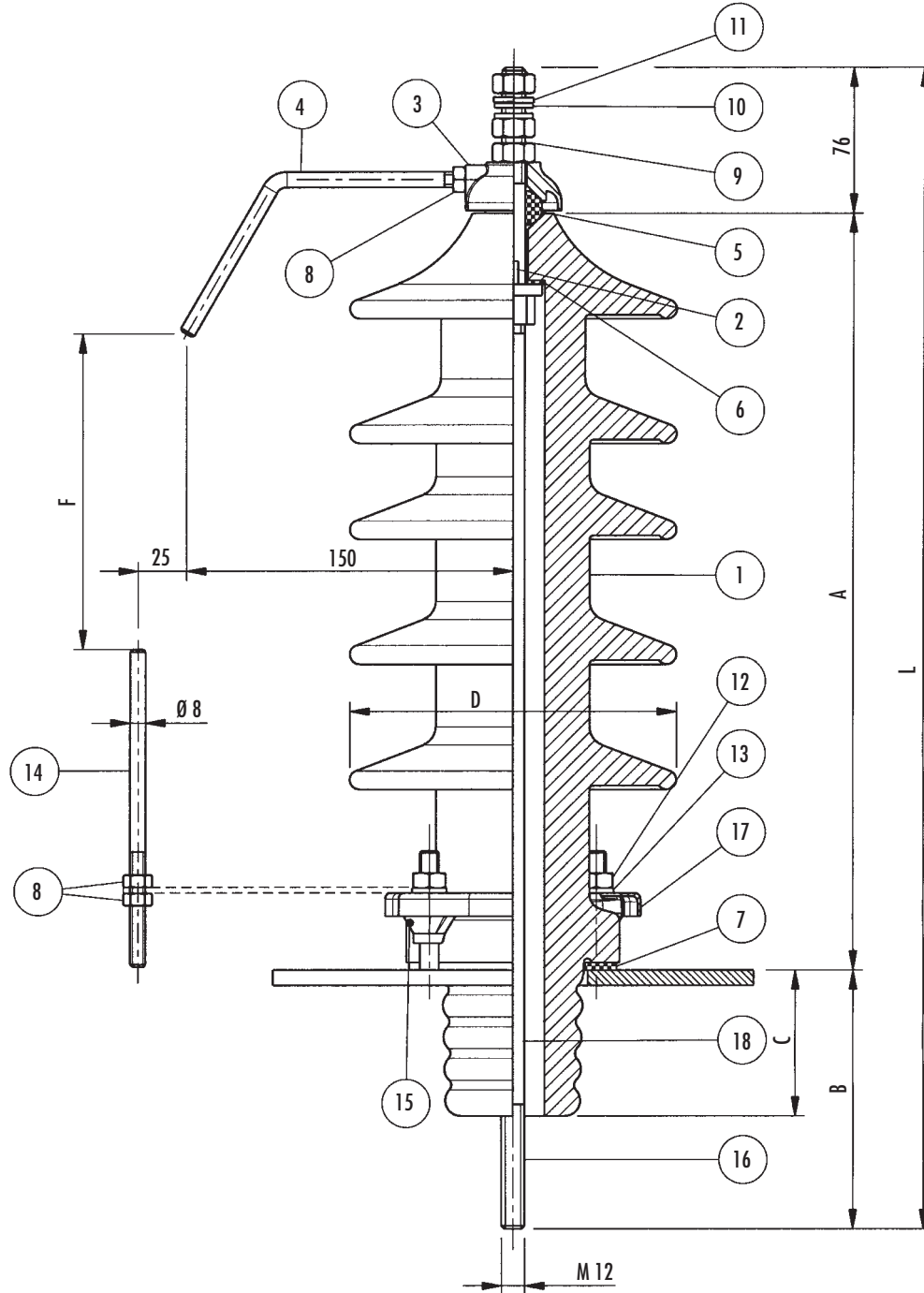

Insulator installation and fastening details: see B15 - Type A

TYPE	A	B	L	C	D	F	N° of sheds	Tank Hole	Weight
C. D. 1320	499	135	710	91	Ø 180	220	11	Ø 78	10.2 kg

250 A

ITEM	DESCRIPTION	Q.TY
1	PORCELAIN	1
2	UPPER BOLT	1
3	CAP	1
4	UPPER HORN	1
5	GASKET	1
6	GASKET	1
7	GASKET	1
8	FULL NUT	3
9	FULL NUT	3
10	WASHER DIN 125 A	2
11	WASHER DIN 127 B	1
12	FULL NUT	4
13	WASHER DIN 125 A	4
14	LOWER HORN	1
15	PRESSBITS	4
16	LOWER BOLT	1
17	FLANGE	1
18	INSULATING TUBE	1

IDENTIFICATION			VOLTAGE TIGHTNESS					
ACCORDING TO STANDARD	RATED VOLTAGE (kV)	RATED CURRENT (A)	LIGHTING IMPULSE (kV)	POWER FREQUENCY (kV)		CREEPAGE DISTANCE MIN. (mm)	ARCING DISTANCE MIN. (mm)	LEE PROTECTED LINE MIN. (mm)
				DRY	WET			
36/250	36	250	170	70	—	1320	—	—

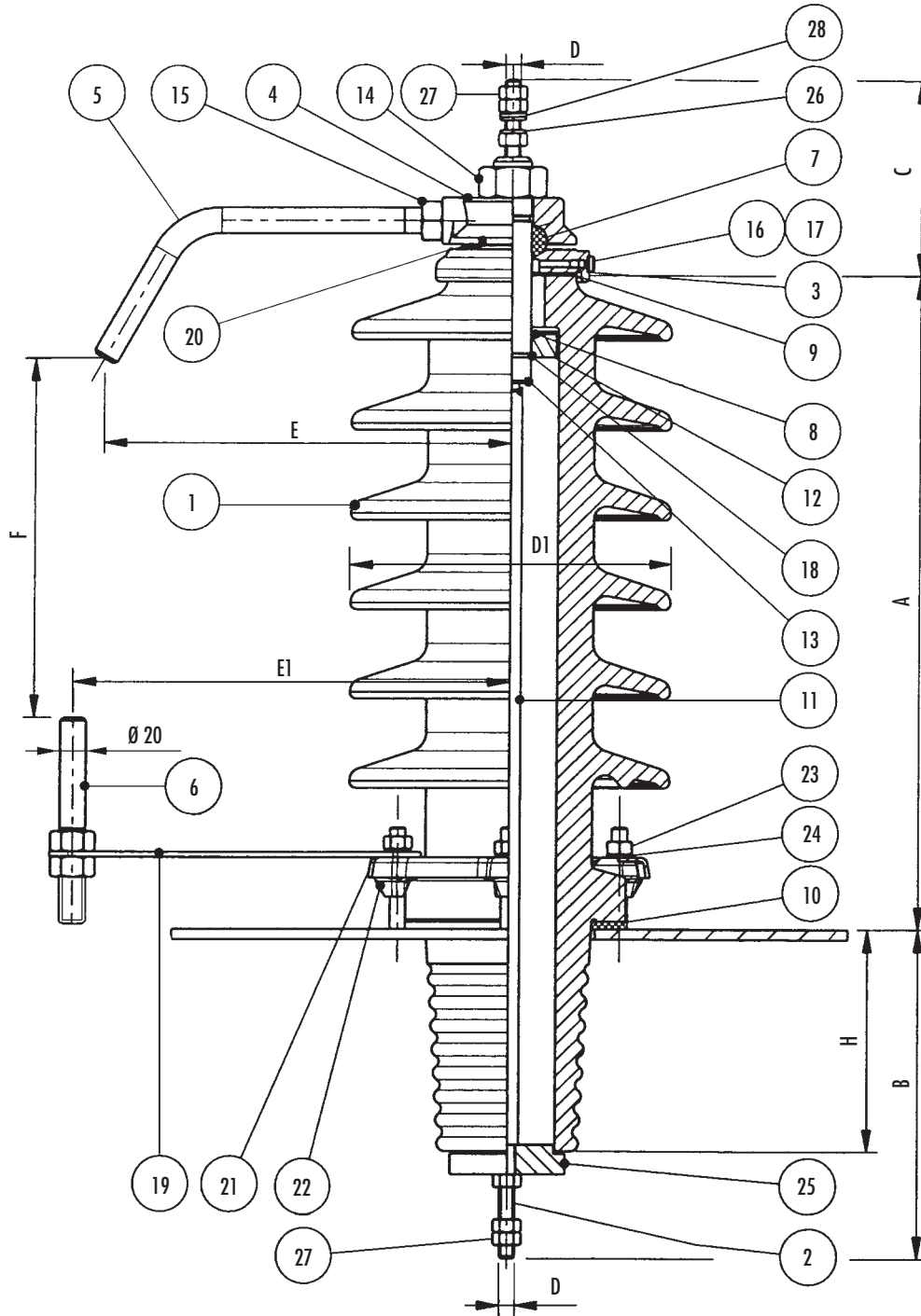

Insulator installation and fastening details: see B15 - Type E1

TYPE	Pos. 2-13	A	B	C	D	D1	E	E1	F	H	N° of sheds	Tank Hole	Weight
52 kV/250 A	BRASS	509	248	153	M12	Ø 250	350	375	305	176	6	Ø 135	24.4 kg
52 kV/630 A	COPPER	509	273	178	M20	Ø 250	350	375	305	176	6	Ø 135	26.4 kg

250 A ÷ 630 A

ITEM	DESCRIPTION	Q.TY
1	PORCELAIN	1
2	LOWER BOLT	1
3	CAP	1
4	WASHER	1
5	UPPER HORN	1
6	LOWER HORN	1
7	GASKET	1
8	GASKET	1
9	GASKET	1
10	GASKET	1
11	INSULATING TUBE	1
12	PRESSURE RING	1
13	UPPER BOLT	1
14	FULL NUT	1
15	FULL NUT	3
16	AIR SCREW	1
17	GASKET	1
18	SCREW DIN 914	2
19	SUPPORT	1
20	CONTACT RING	1
21	FLANGE	1
22	PRESSBITS	6
23	FULL NUT	6
24	WASHER DIN 125 A	6
25	CENTER RING	1
26	WASHER DIN 125 A	2
27	FULL NUT	6
28	WASHER DIN 127 B	1

IDENTIFICATION			VOLTAGE TIGHTNESS					
COMEM DESIGN	RATED VOLTAGE (kV)	RATED CURRENT (A)	LIGHTING IMPULSE (kV)	POWER FREQUENCY (kV)		CREEPAGE DISTANCE MIN. (mm)	ARCING DISTANCE MIN. (mm)	LEE PROTECTED LINE MIN. (mm)
				DRY	WET			
52/250	52	250	250	—	95	950	480	340
52/630	52	630	250	—	95	950	480	340

6300 A

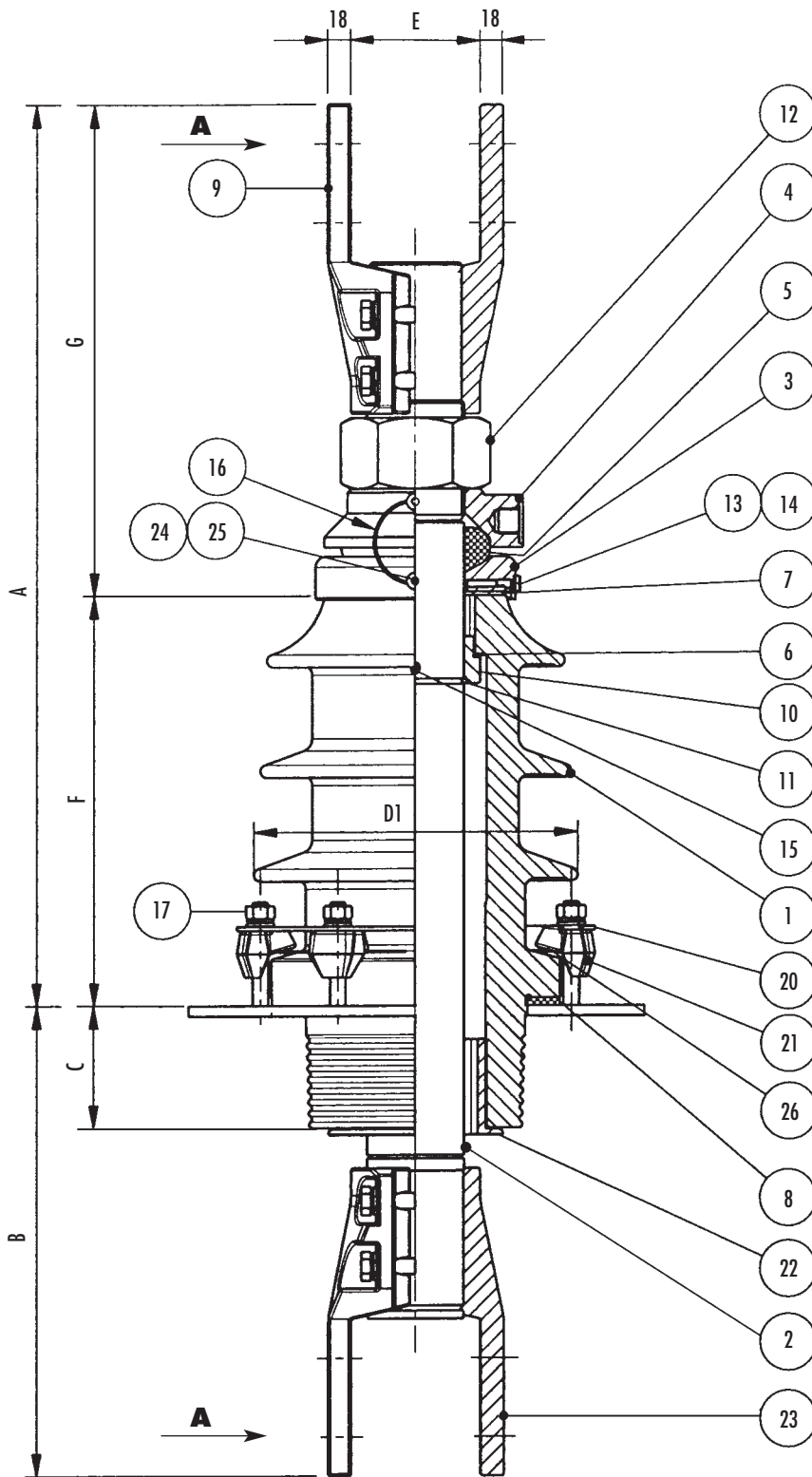

Insulator installation and fastening details: see B15 - Type I

TYPE	A	B	C	D1	E	F	G	N° of shads	Tank Hole	Weight
24 kV/6300 A	690	360	94	Ø 250	100	316	380	3	Ø 176	48 kg

6300 A

ITEM	DESCRIPTION	Q.TY
1	PORCELAIN	1
2	BOLT	1
3	CAP	1
4	WASHER	1
5	GASKET	1
6	GASKET	1
7	GASKET	1
8	GASKET	1
9	UPPER FLAG	2
10	PRESSURE RING	1
11	STOP RING	1
12	FULL NUT	1
13	AIR SCREW	1
14	GASKET	1
15	SCREW DIN 914	2
16	CABLE LEAD	1
17	FULL NUT	14
18	WASHER DIN 125 A	14
19	WASHER	14
20	FLANGE	1
21	PRESSBITS	6
22	CENTER RING	1
23	LOWER FLAG	2
24	SCREW	2
25	WASHER DIN 125 A	2
26	RING OF COMPENSATION	1
27	SCREW DIN 933	4

IDENTIFICATION			VOLTAGE TIGHTNESS			CREEPAGE DISTANCE MIN. (mm)	ARCING DISTANCE MIN. (mm)	LEE PROTECTED LINE MIN. (mm)
COMEM DESIGN	RATED VOLTAGE (kV)	RATED CURRENT (A)	LIGHTING IMPULSE (kV)	POWER FREQUENCY (kV)				
				DRY	WET			
24/6300	24	6300	125	-	50	440	155	90

A VIEW

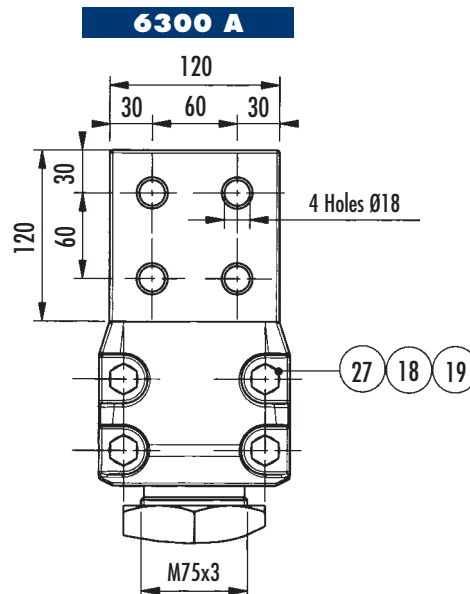

4500 A

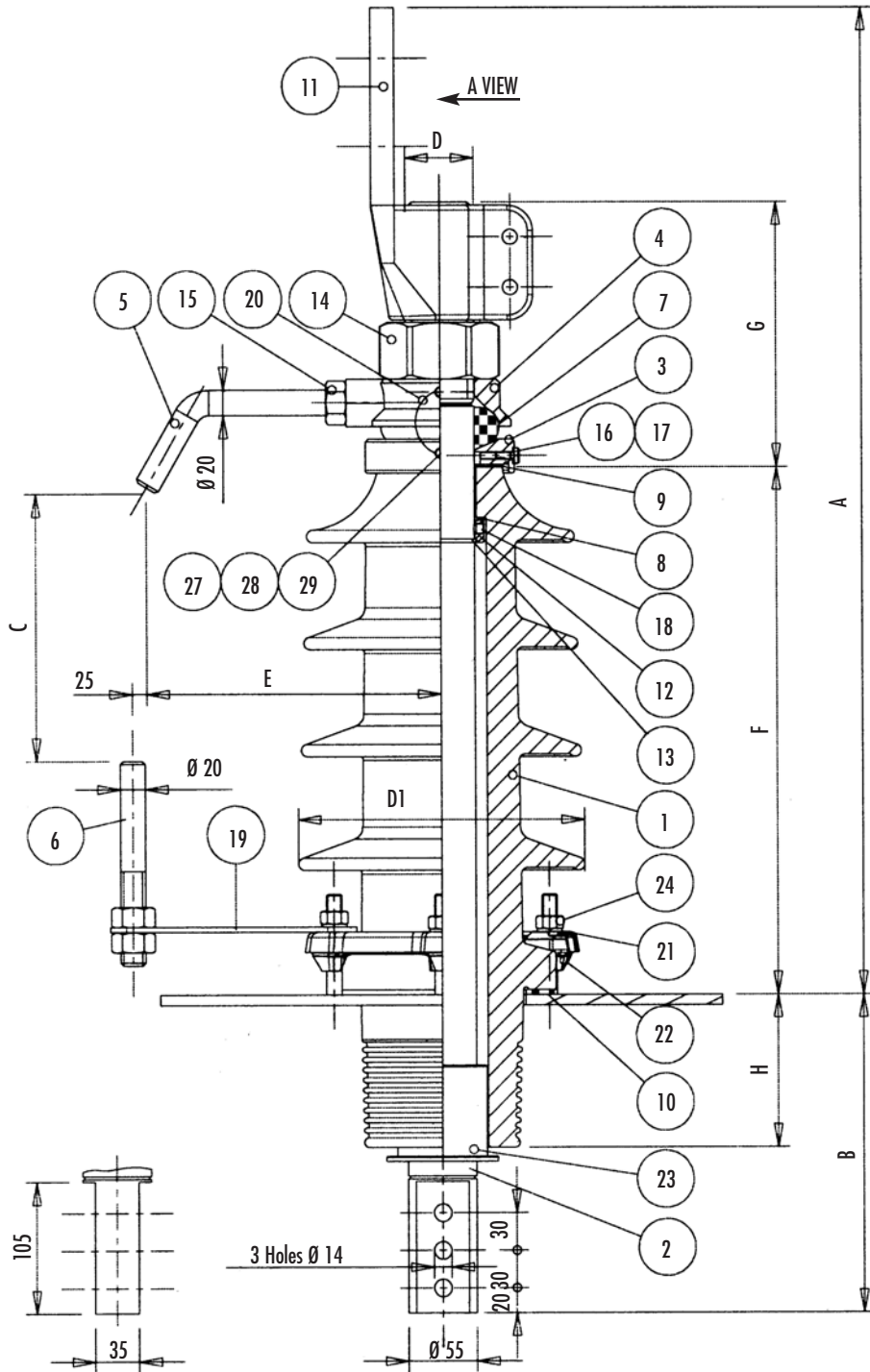

Insulator installation and fastening details: see B15 - Type D

TYPE	A	B	C	D	D1-Max	E	F	G	H	N° of sheds	Hole Tank	Weight
12 kV/4500 A	600	218	70	M55x3	Ø 190	235	239	210	86	2	Ø 135	36 kg
24 kV/4500 A	675	226	100	M55x3	Ø 210	235	314	210	96	3	Ø 135	40 kg
36 kV/4500 A	780	253	130	M55x3	Ø 230	235	419	210	121	4	Ø 135	46 kg

4500 A

ITEM	DESCRIPTION	Q.TY
1	PORCELAIN	1
2	BOLT	1
3	CAP	1
4	WASHER	1
5	UPPER HORN	1
6	LOWER HORN	1
7	GASKET	1
8	GASKET	1
9	GASKET	1
10	GASKET	1
11	FLAG TYPE 4500 A	1
12	PRESSURE RING	1
13	STOP RING	1
14	FULL NUT	1
15	FULL NUT	3
16	AIR SCREW	1
17	GASKET	1
18	SCREW DIN 914	2
19	SUPPORT	1
20	CABLE LEAD	1
21	FLANGE	1
22	PRESSBITS	6
23	CENTER-RING	1
24	FULL NUT	6
25	WASHER DIN 125 A	8
26	SCREW DIN 933	2
27	WASHER DIN 125 A	2
28	WASHER DIN 127 B	2
29	SCREW	2

IDENTIFICATION			VOLTAGE TIGHTNESS			CREEPAGE DISTANCE MIN. (mm)	ARCING DISTANCE MIN. (mm)	LEE PROTECTED LINE MIN. (mm)
COMEM PRODUCT	RATED VOLTAGE (kV)	RATED CURRENT (A)	LIGHTING IMPULSE (kV)	POWER FREQUENCY (kV)				
				DRY	WET			
12/4500	12	4500	75	—	28	295	85	48
24/4500	24	4500	125	—	50	445	155	90
36/4500	36	4500	170	—	70	635	220	168

A VIEW

4500 A

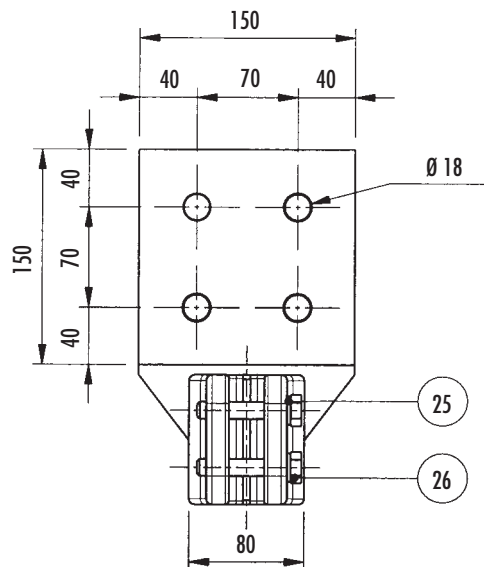

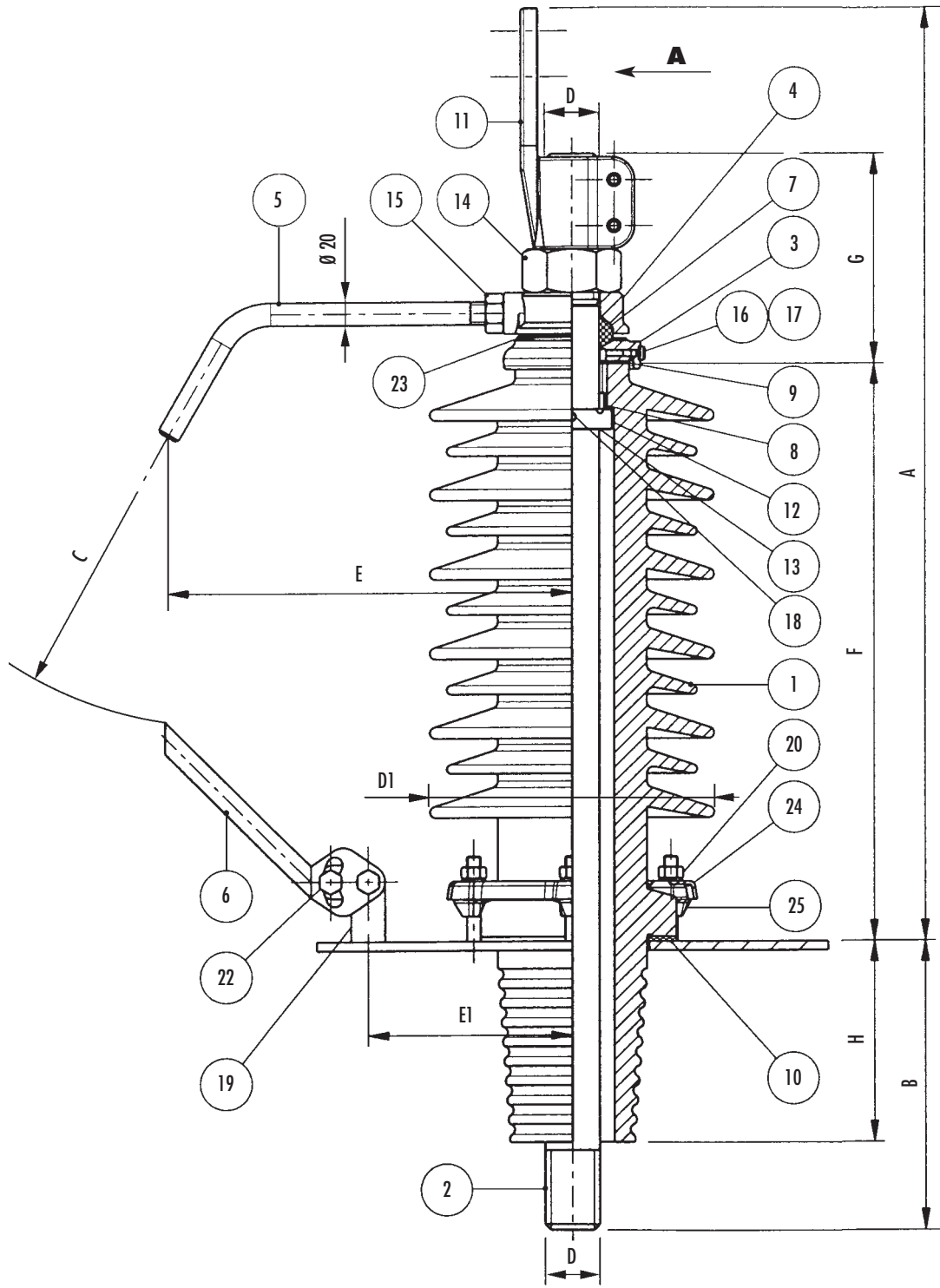

Insulator installation and fastening details: see B15 - Type E

TYPE	A	B	C	D	D1	E	E1	F	G	H	N° of sheds	Tank Hole	Weight
52 kV/1000 A	730	251	305	M30x2	∅ 250	350	175	511	148	176	11	∅ 135	35.2 kg
52 kV/2000 A	807	251	305	M42x3	∅ 250	350	175	511	178	176	11	∅ 135	44.9 kg
52 kV/3150 A	836	251	305	M48x3	∅ 250	355	180	511	183	176	11	∅ 135	49.2 kg

1000 A ÷ 3150 A

ITEM	DESCRIPTION	Q.TY
1	PORCELAIN	1
2	BOLT	1
3	CAP	1
4	WASHER	1
5	UPPER HORN	1
6	LOWER HORN	1
7	GASKET	1
8	GASKET	1
9	GASKET	1
10	GASKET	1
11	FLAG DIN 43675	1
12	PRESSURE RING	1
13	STOP RING	1
14	FULL NUT	1
15	FULL NUT	1
16	AIR SCREW	1
17	GASKET	1
18	SCREW DIN 914	2
19	SUPPORT	1
20	FULL NUT	8
21	WASHER DIN 125 A	8
22	SCREW DIN 933	2
23	CONTACT RING	1
24	FLANGE	1
25	PRESSBITS	6
26	SCREW DIN 933	2

IDENTIFICATION			VOLTAGE TIGHTNESS			CREEPAGE DISTANCE MIN. (mm)	ARCING DISTANCE MIN. (mm)	LEE PROTECTED LINE MIN. (mm)
COMEM DESIGN	RATED VOLTAGE (kV)	RATED CURRENT (A)	LIGHTING IMPULSE (kV)	POWER FREQUENCY (kV)				
				DRY	WET			
—	52	1000	250	—	95	1430	480	340
—	52	2000	250	—	95	1430	480	340
—	52	3150	250	—	95	1430	480	340

A VIEW

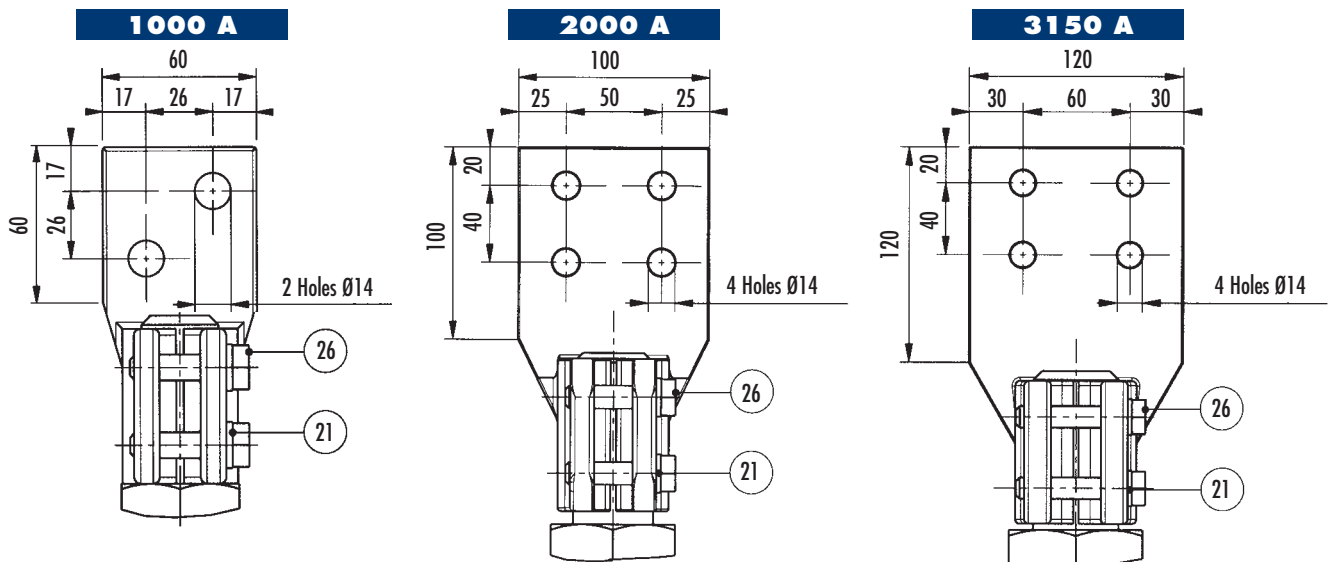

5000 A ÷ 8000 A

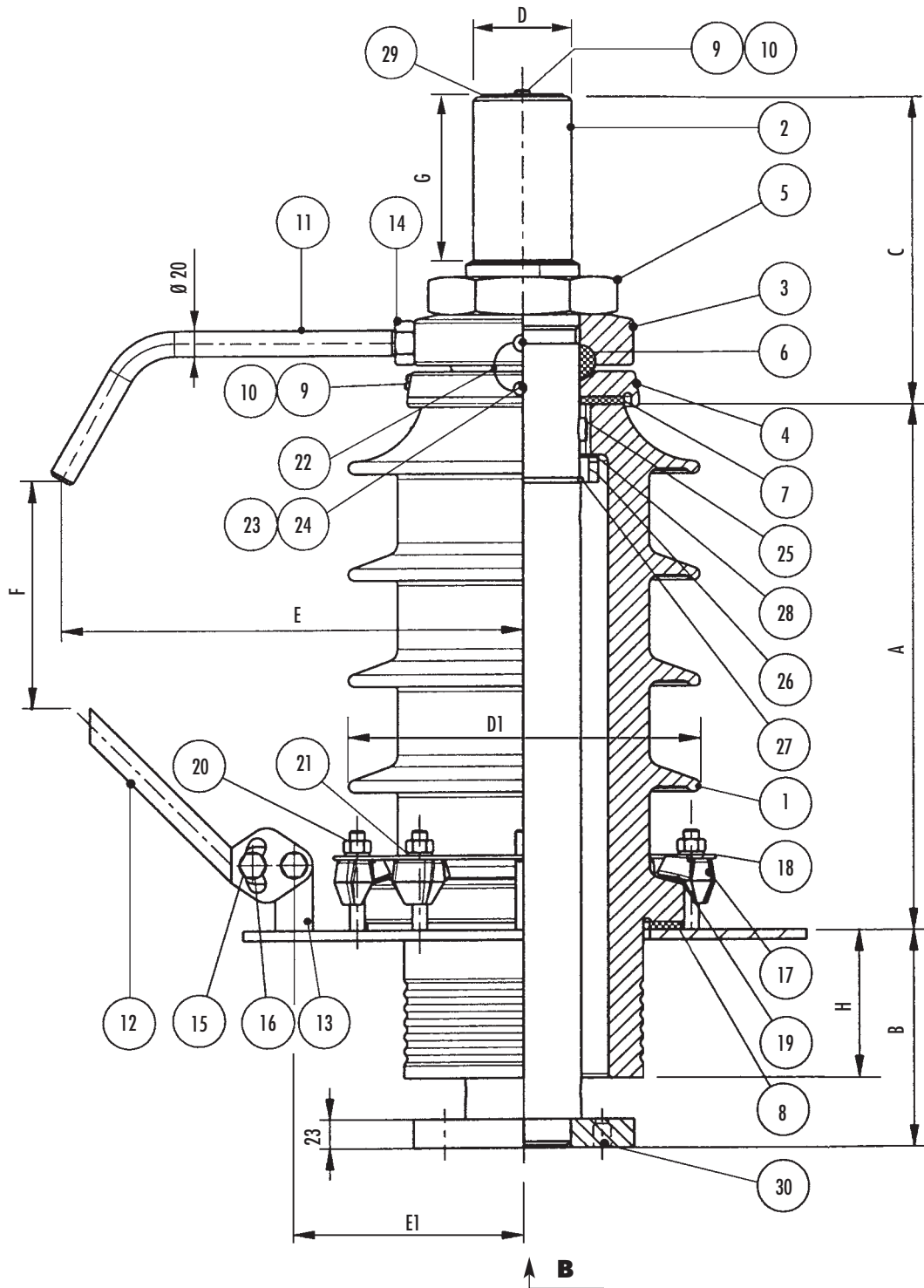

Insulator installation and fastening details: see B15 - Type F

TYPE	A	B	C	D	D1	E	E1	F	H	G	N° of sheds	Tank Hole	Weight
24 kV/5000 A	326	150	214	∅ 78	∅ 275	295	190	155	94	100	3	∅ 200	52.5 kg
36 kV/5000 A	421	175	214	∅ 78	∅ 280	320	190	220	119	100	4	∅ 200	56.5 kg
24 kV/8000 A	326	150	244	∅ 78	∅ 275	295	190	155	94	130	3	∅ 200	54 kg
36 kV/8000 A	421	175	244	∅ 78	∅ 280	320	190	220	119	130	4	∅ 200	58 kg

5000 A ÷ 8000 A

ITEM	DESCRIPTION	Q.TY
1	PORCELAIN	1
2	BOLT	1
3	WASHER	1
4	CAP	1
5	NUT	1
6	GASKET	1
7	GASKET	1
8	GASKET	1
9	AIR SCREW	2
10	GASKET	2
11	UPPER HORN	1
12	LOWER HORN	1
13	SUPPORT	1
14	FULL NUT	1
15	SCREW DIN 914	2
16	WASHER DIN 125 A	2
17	PRESSBITS	10
18	FLANGE	1
19	RING OF COMPENSATION	1
20	FULL NUT	12
21	WASHER DIN 125 A	10
22	CABLE-LEAD	1
23	WASHER DIN 125 A	2
24	SCREW	2
25	PIN	1
26	PRESSURE RING	1
27	STOP RING	1
28	GASKET	1
29	COPPER DISC	1
30	LOWER WASHER	1

IDENTIFICATION			VOLTAGE TIGHTNESS					
ACCORDING TO STANDARD	RATED VOLTAGE (kV)	RATED CURRENT (A)	LIGHTING IMPULSE (kV)	POWER FREQUENCY (kV)		CREEPAGE DISTANCE (mm)*	ARCING DISTANCE (mm)*	LEE PROTECTED LINE MIN. (mm)
				DRY	WET			
				DIN 42541-83	24			
DIN 42541-83	36	5000	170	—	70	555	355	140
DIN 42541-83	24	8000	125	—	50	470	260	105
DIN 42541-83	36	8000	170	—	70	555	355	140

*Data reported from DIN 42541

B VIEW

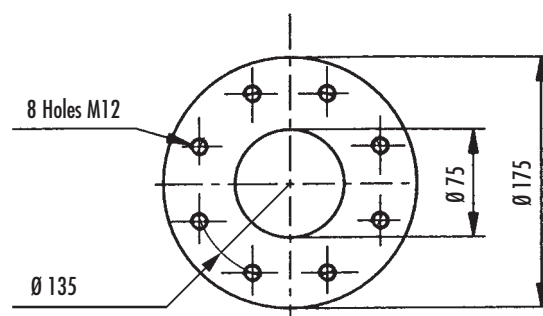

5000 A ÷ 8000 A

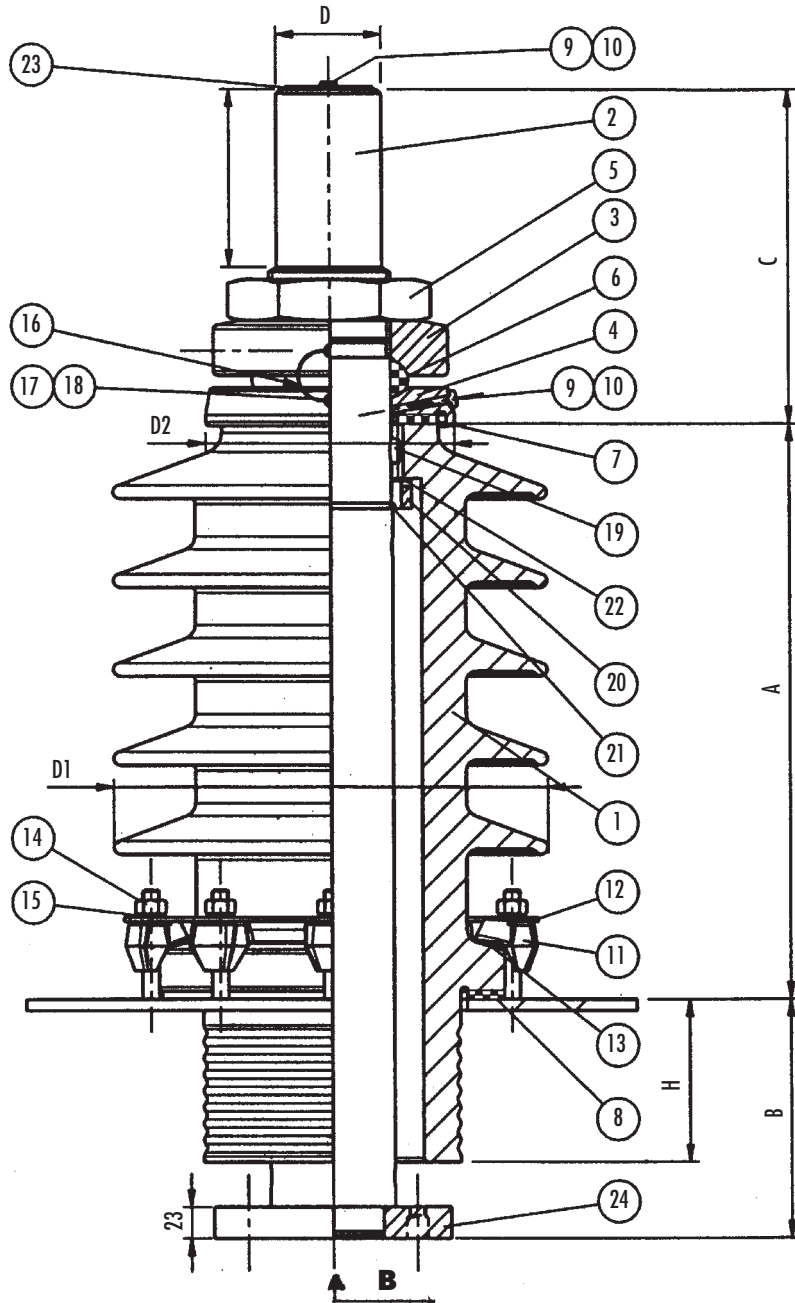

Insulator installation and fastening details: see B15 - Type F

TYPE	A	B	C	D	D1	D2	G	H	Insulator type	N° of sheds	Tank Hole	Weight
24 kV/5000 A-P2	326	150	214	Ø 78	Ø 285	Ø 184	100	94	24-P2	3	Ø 200	66.5 kg
24 kV/8000 A-P2	326	150	244	Ø 78	Ø 285	Ø 184	130	94	24-P2	3	Ø 200	68 kg
24 kV/5000 A-P4	421	175	214	Ø 78	Ø 320	Ø 184	100	119	36-P2	5	Ø 200	81 kg
24 kV/8000 A-P4	421	175	244	Ø 78	Ø 320	Ø 184	130	119	36-P2	5	Ø 200	82.5 kg
36 KV/5000 A-P2	421	175	214	Ø 78	Ø 320	Ø 184	100	119	36-P2	5	Ø 200	81 kg
36 kV/8000 A-P2	421	175	244	Ø 78	Ø 320	Ø 184	130	119	36-P2	5	Ø 200	82.5 kg
36 kV/5000 A-P3	421	175	214	Ø 78	Ø 295	Ø 184	100	119	36-P3	9	Ø 200	83.5 kg
36 kV/8000 A-P3	421	175	244	Ø 78	Ø 295	Ø 184	130	119	36-P3	9	Ø 200	85 kg

5000 A ÷ 8000 A

ITEM	DESCRIPTION	Q.TY
1	PORCELAIN	1
2	BOLT	1
3	WASHER	1
4	CAP	1
5	NUT	1
6	GASKET	1
7	GASKET	1
8	GASKET	1
9	AIR SCREW	1
10	GASKET	1
11	PRESSBITS	10
12	FLANGE	1
13	RING OF COMPENSATION	1
14	NUT	10
15	WASHER DIN 125 A	10
16	CABLE-LEAD	1
17	WASHER DIN 125 A	2
18	SCREW	2
19	PIN	1
20	PRESSURE RING	1
21	STOP RING	1
22	GASKET	1
23	COPPER DISC	1
24	LOWER WASHER	1

IDENTIFICATION			VOLTAGE TIGHTNESS						
ACCORDING TO STANDARD	RATED VOLTAGE (kV)	RATED CURRENT (A)	LIGHTING IMPULSE (kV)	POWER FREQUENCY (kV)		CREEPAGE DISTANCE (mm)*	ARCING DISTANCE (mm)*	LEE PROTECTED LINE MIN. (mm)	POLLUTION LEVEL
				DRY	WET				
EN 50243	24	5000	125	50	50	480	270	125	P2
EN 50243	24	8000	125	50	50	480	270	125	P2
EN 50243	24	5000	125	50	50	744	380	300	P4
EN 50243	24	8000	125	50	50	744	380	300	P4
EN 50243	36	5000	170	70	70	720	380	300	P2
EN 50243	36	8000	170	70	70	720	380	300	P2
EN 50243	36	5000	170	70	70	900	370	385	P3
EN 50243	36	8000	170	70	70	900	370	385	P3

*Data reported from EN 50243

B VIEW

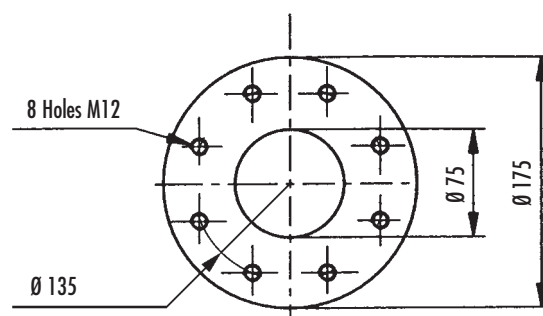

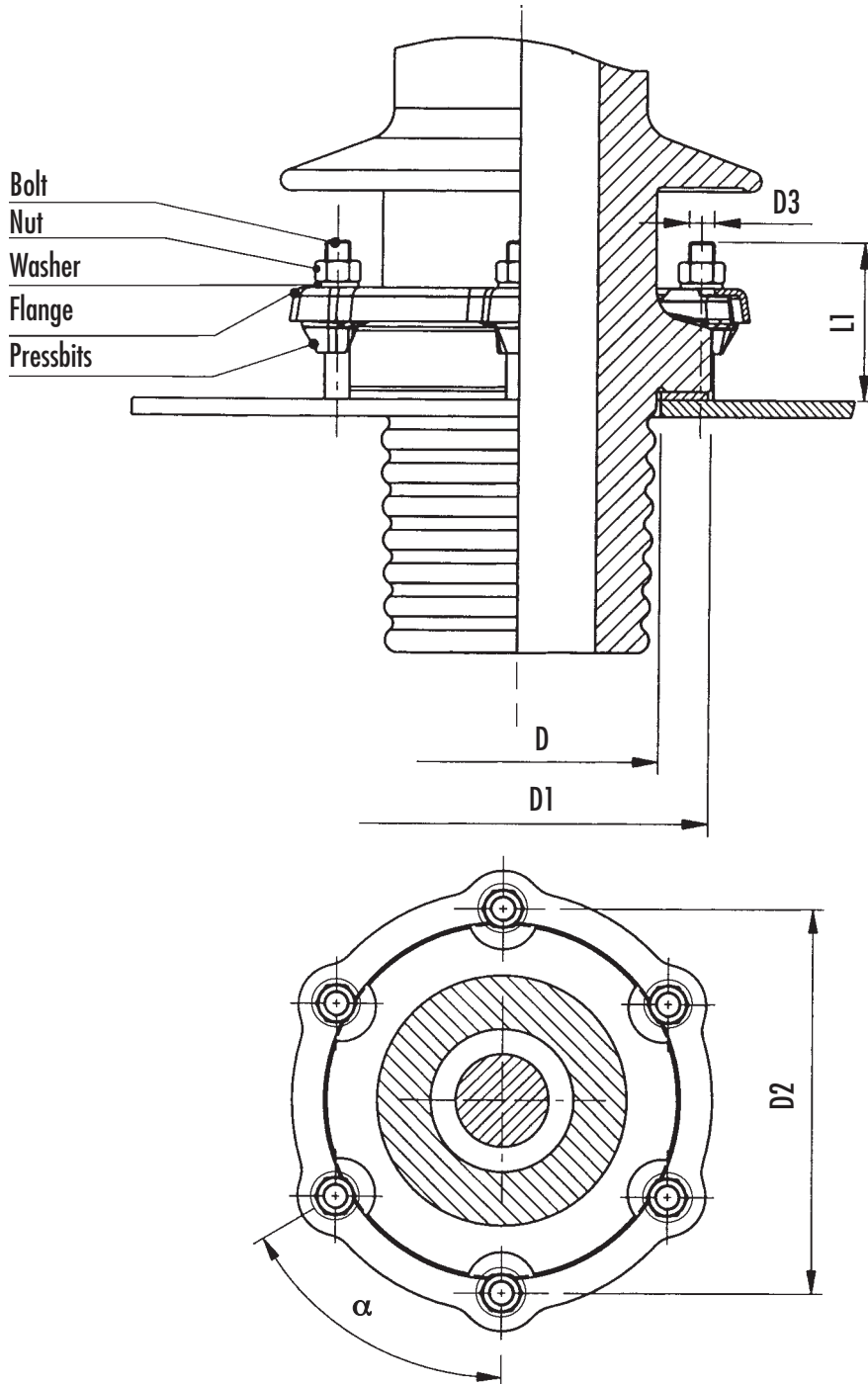

FIXING	TYPE OF BUSHING	α	N° of bolt	D \pm 1	D1	D2	D3	L1
A	12kv-36kv/250A DIN	90°	4	Ø 78	Ø 111	Ø 123	M10	55
A1	12kv-36kv/250A CENELEC	90°	4	Ø 80	Ø 111	Ø 123	M10	55
B	12kv-36kv/630A DIN - CENELEC	60°	6	Ø 90	Ø 128	Ø 140	M10	55
C	12kv-36kv/1000A DIN	60°	6	Ø 110	Ø 163	Ø 180	M12	65
D	12kv-36kv/2000A÷4500A DIN-COMEM	60°	6	Ø 135	Ø 183	Ø 200	M12	70
E	52kv/1000A - 3150A DIN	60°	6	Ø 135	Ø 183	Ø 200	M12	70
E1	52kv/250A - 630A	60°	6	Ø 135	Ø 183	Ø 200	M12	70
F	24kv-36kv/5000A - 8000A DIN - EN	36°	10	Ø 200	Ø 255	Ø 280	M12	75
G	12kv-36kv/1250A CENELEC	60°	6	Ø 110	Ø 165	Ø 185	M12	65
H	12kv-36kv/2000A - 3150A CENELEC	60°	6	Ø 135	Ø 185	Ø 205	M12	70
I	24kv-6300A COMEM	60°	6	Ø 176	Ø 223	Ø 240	M12	75

FIXING INSTRUCTION

B16

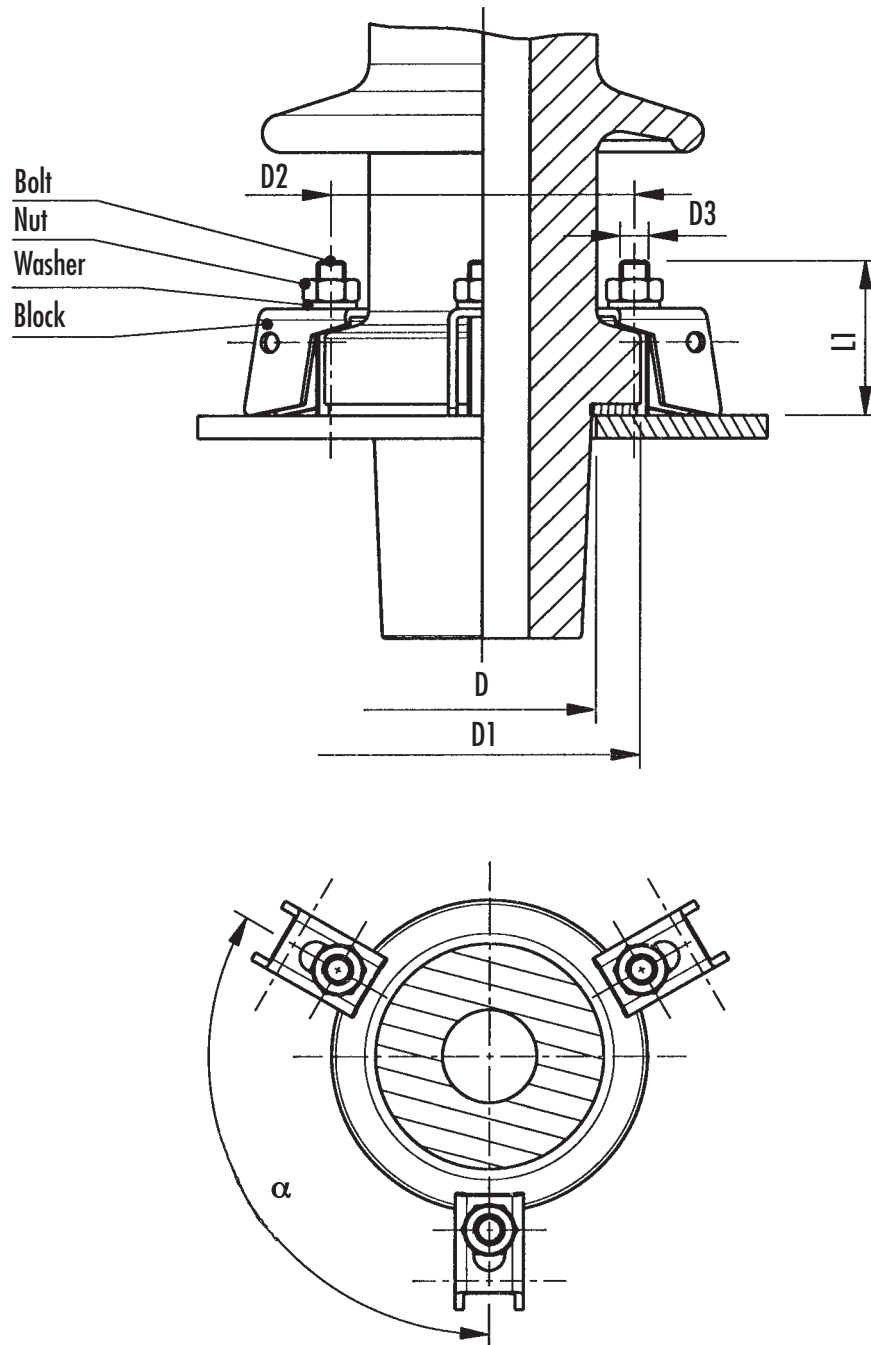

FIXING	TYPE OF BUSHING	α	N° of bolt	$D \pm 1$	D1	D2	D3	L1
A	12kV-36kV / 250A DIN	120°	3	Ø 78	Ø 111	Ø 123	M10	55
B	12kV-36kV / 630A DIN - CENELEC	90°	4	Ø 90	Ø 128	Ø 140	M10	55
C	12kV-36kV / 250A CENELEC	120°	3	Ø 80	Ø 111	Ø 123	M10	55

WARNING: Fill out the sheet only if it is different from the specific relevant standard

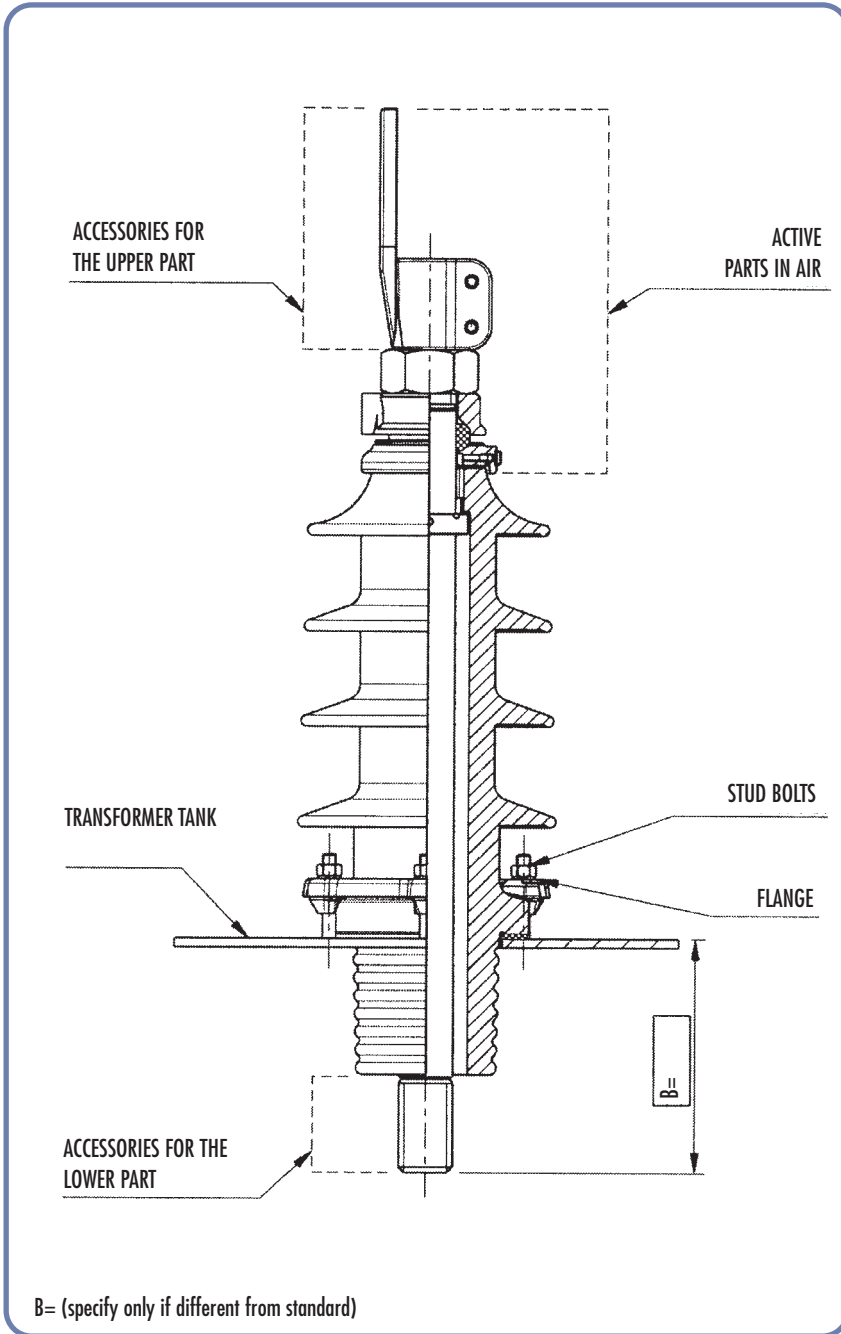

• VOLTAGE (kV):

• CURRENT (A):

• RELEVANT STANDARD:

- DIN
- COMEM Catalogue page:
- CENELEC
- Other:

• ACTIVE PARTS IN AIR:

- Tinned 10 µm
- Silver-plated 3 µm
- Other:

• FIXING COMPONENTS:

- Galvanized steel
- Stainless steel

• FLANGE:

- Aluminum
- Galvanized steel
- Stainless steel

• GASKETS:

- NBR (-25 °C/+115 °C)
- NBR (-40 °C/+115 °C)
- VITON (-10 °C/+150 °C)
- Special type:

• ARCING HORNS: YES NO

• CONSTRUCTION DETAILS ACCORDING TO CUSTOMER SPECIFICATIONS:

• ACCESSORIES FOR THE UPPER PART:

Flag: Type: Customer drawing:

• ACCESSORIES FOR THE LOWER PART:

Flag: Type: Customer drawing:

Nuts: Type:

• NOTES:

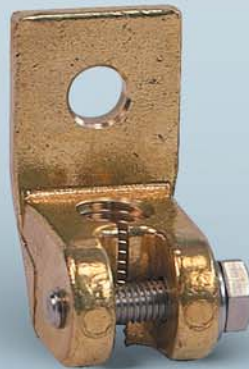

630 A

DP Type

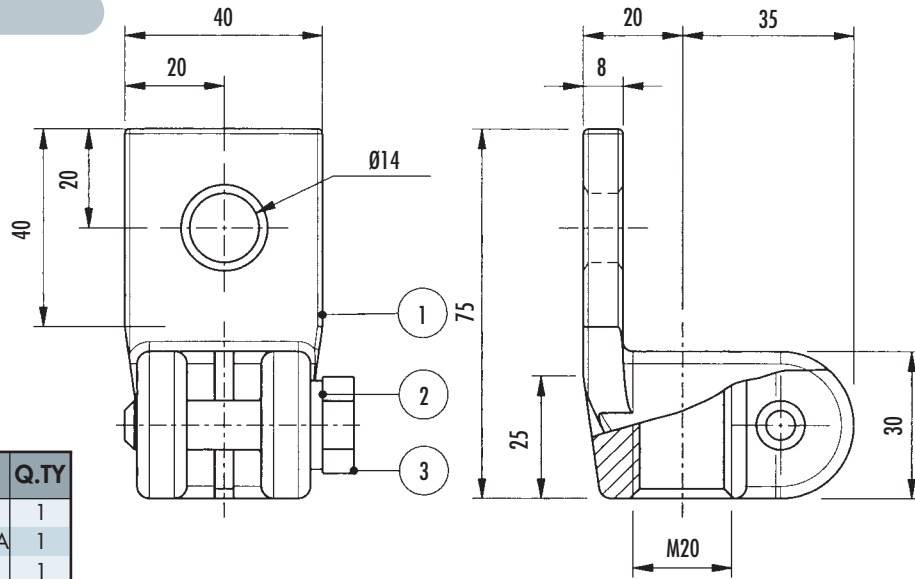

ITEM	DESCRIPTION	Q.TY
1	FLAG DP	1
2	WASHER DIN 125 A	1
3	SCREW DIN 933	1

DR Type

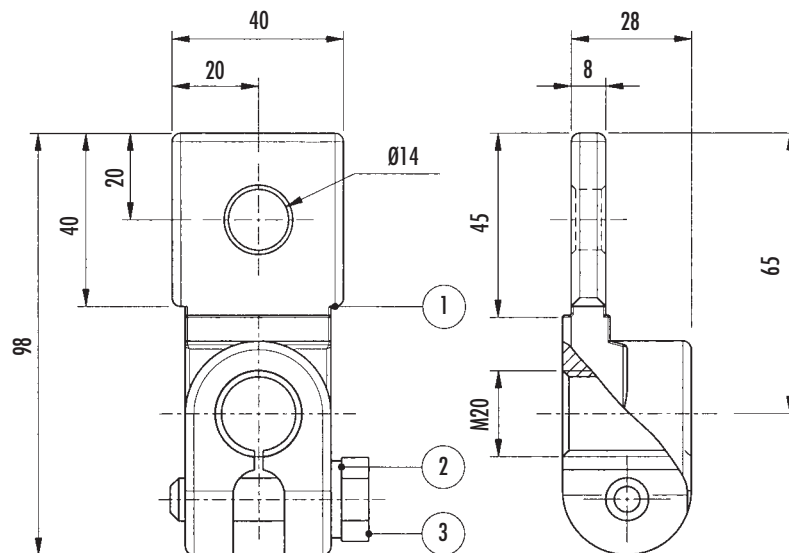

ITEM	DESCRIPTION	Q.TY
1	FLAG DR	1
2	WASHER DIN 125 A	1
3	SCREW DIN 933	1

DIN 43675-75

C

1000 A

EP Type

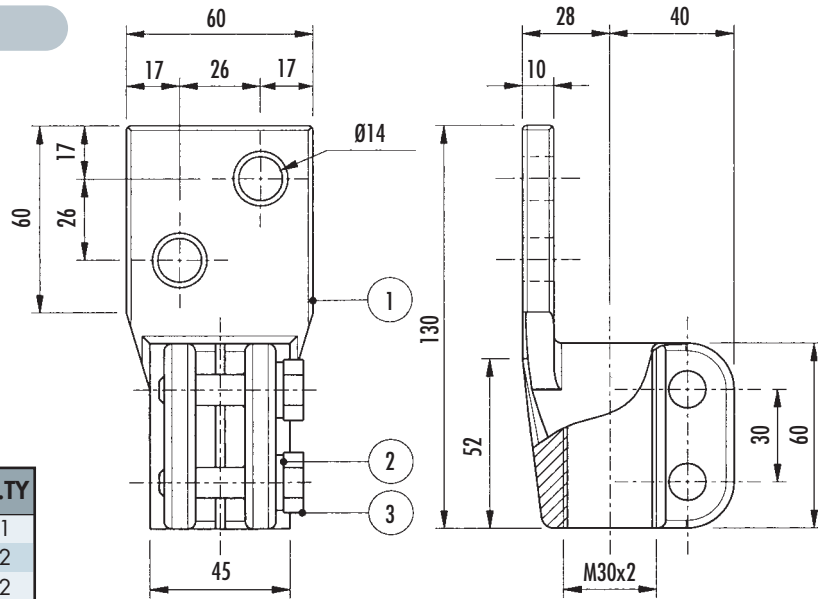

ITEM	DESCRIPTION	Q.TY
1	FLAG EP	1
2	WASHER DIN 125 A	2
3	SCREW DIN 933	2

ER Type

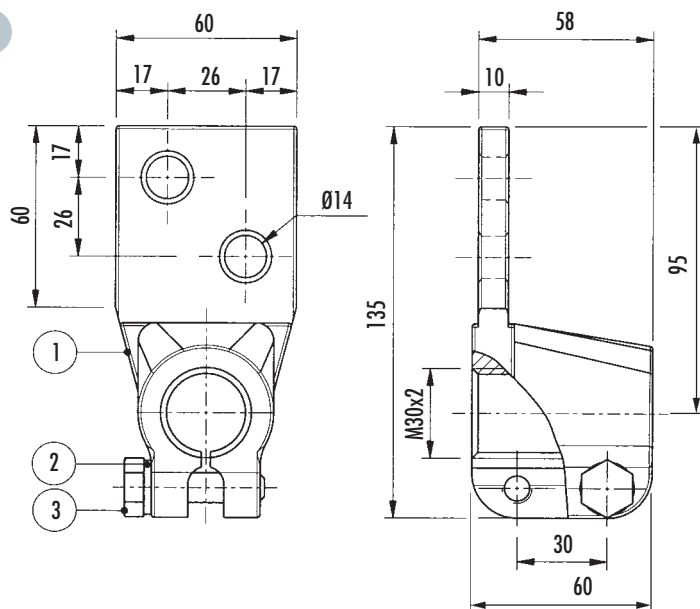

ITEM	DESCRIPTION	Q.TY
1	FLAG ER	1
2	WASHER DIN 125 A	2
3	SCREW DIN 933	2

2000 A - 3150 A

FP Type

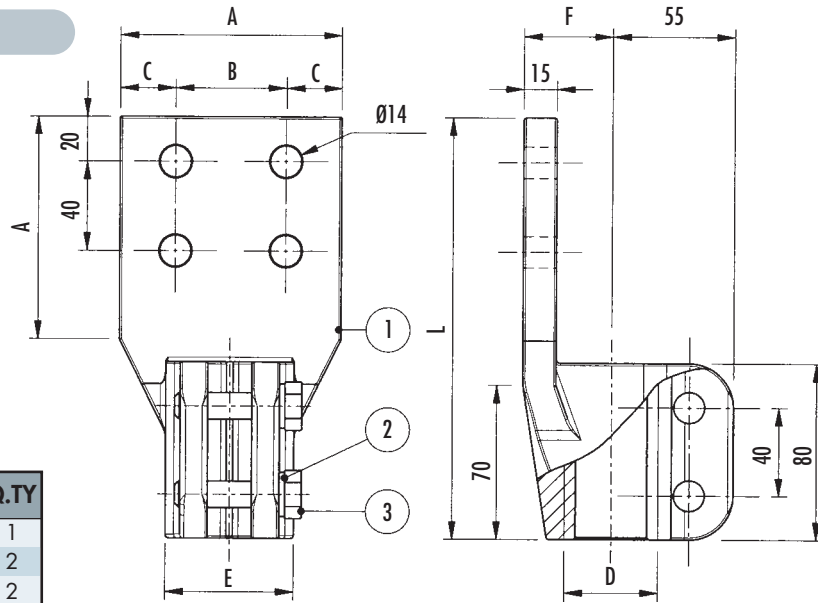

ITEM	DESCRIPTION	Q.TY
1	FLAG FP	1
2	WASHER DIN 125 A	2
3	SCREW DIN 933	2

CURRENT	D		A	B	C	E	F	L	Weight
2000 A	M42x3	42H9	100	50	25	58	40	190	3.5 kg
3150 A	M48x3	48H9	120	60	30	68	45	210	4.5 kg

FR Type

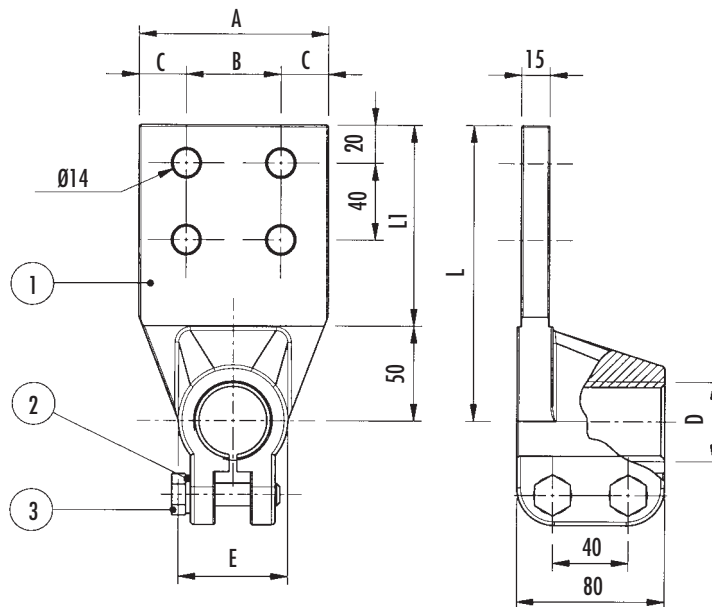

ITEM	DESCRIPTION	Q.TY
1	FLAG FR	1
2	WASHER DIN 125 A	2
3	SCREW DIN 933	2

CURRENT	D		A	B	C	E	L	L1	Weight
2000 A	M42x3	42H9	100	50	25	58	155	105	3.5 kg
3150 A	M48x3	48H9	120	60	30	68	175	125	4.5 kg

DIN 43675-75

C

5000 A

TP 78-120 Type

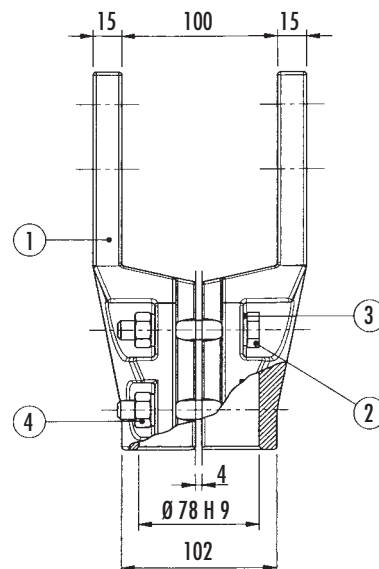
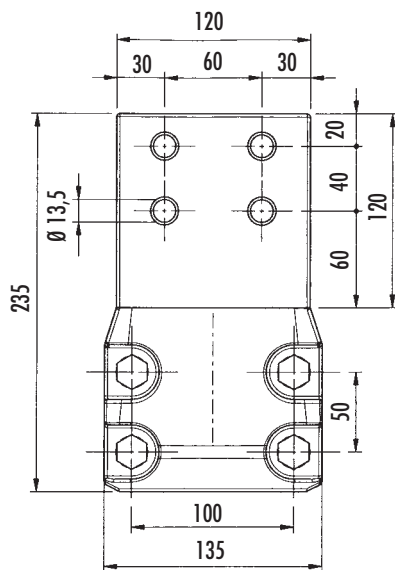

ITEM	DESCRIPTION	Q.TY
1	SEMIFLAG	2
2	WASHER DIN 125 A	4
3	SCREW DIN 933	4
4	FULL NUT	4

8000 A

TP 78-180 Type

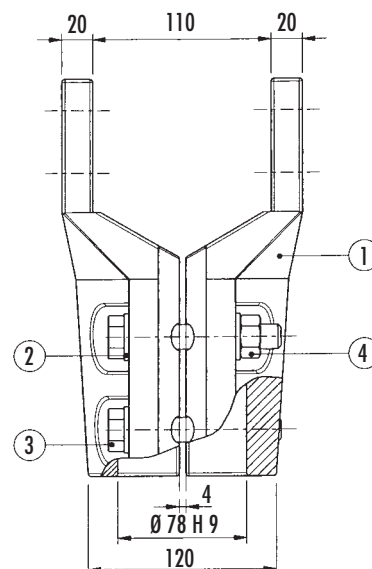
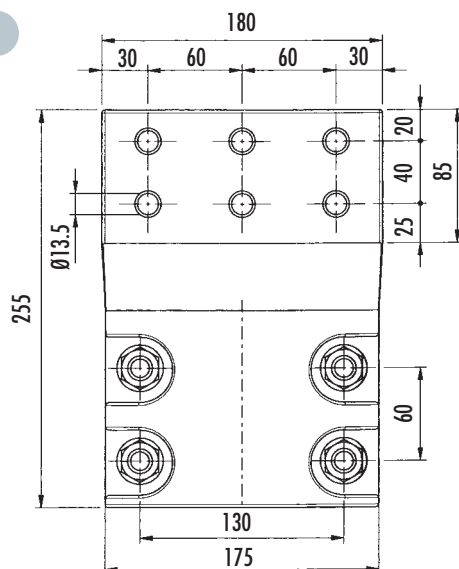

ITEM	DESCRIPTION	Q.TY
1	SEMIFLAG	2
2	WASHER DIN 125 A	4
3	SCREW DIN 933	4
4	FULL NUT	4

630 A - 1000 A

6 Type - 10 Type

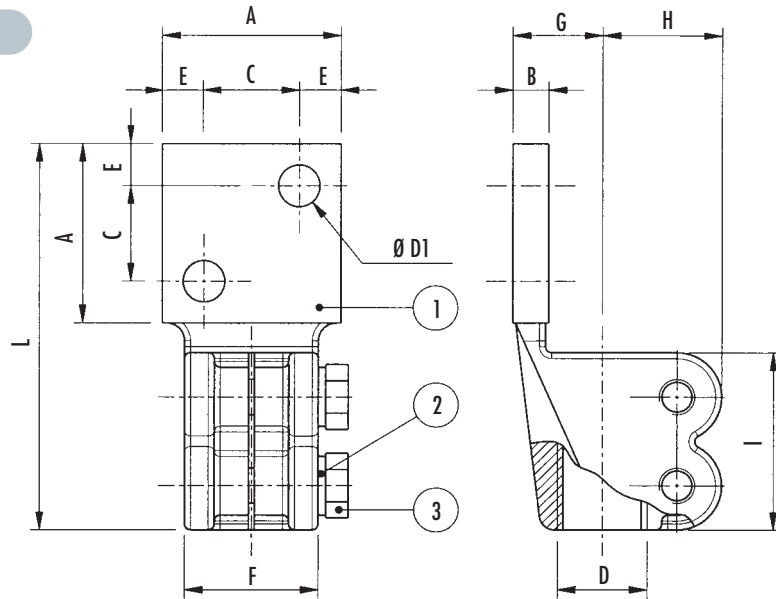

ITEM	DESCRIPTION	Q.TY
1	FLAG	1
2	WASHER DIN 125 A	2
3	SCREW DIN 933	2

TYPE	CURRENT	A	B	C	D	D1	E	F	G	H	I	L	Weight
6	630 A	40	11	20	M20	10	10	30	23	28	40	85	0.45 kg
10	1000 A	60	12	32	M30x2	14	14	45	30	40	60	130	1.2 kg

2000 A - 3150 A

20 Type - 31 Type

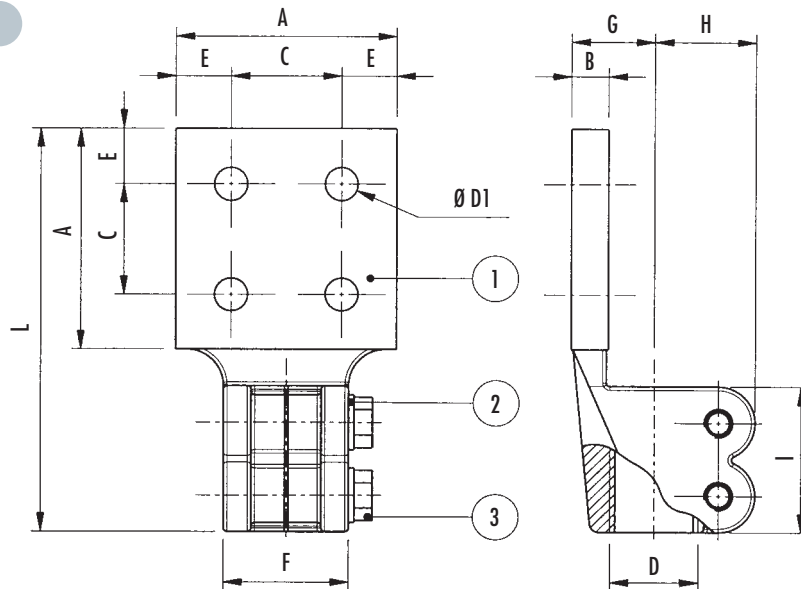

ITEM	DESCRIPTION	Q.TY
1	FLAG	1
2	WASHER DIN 125 A	2
3	SCREW DIN 933	2

TYPE	CURRENT	A	B	C	D	D1	E	F	G	H	I	L	Weight
20	2000 A	100	20	50	M42x3	18	25	58	45	55	80	195	4 kg
31	3150 A	120	20	60	M48x3	18	30	68	45	55	80	220	4.9 kg

1000 A

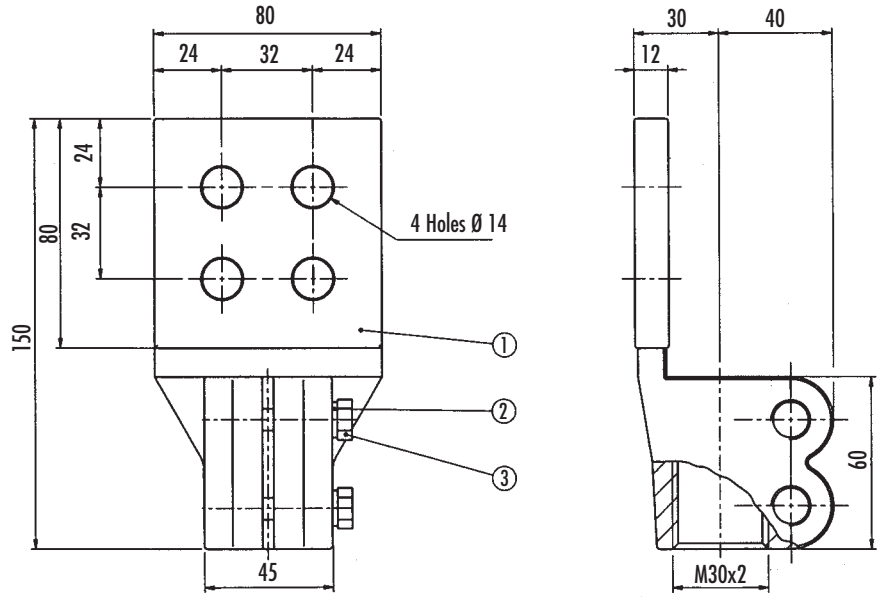

ITEM	DESCRIPTION	Q.TY
1	FLAG	1
2	WASHER DIN 125 A	2
3	SCREW DIN 933	2

2000 A - 3150 A

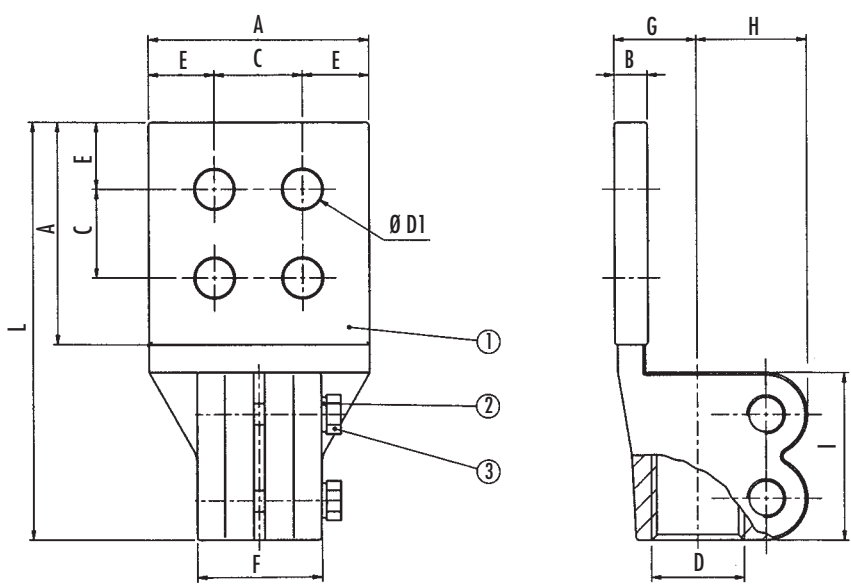

ITEM	DESCRIPTION	Q.TY
1	FLAG	1
2	WASHER DIN 125 A	2
3	SCREW DIN 933	2

CURRENT	A	B	C	D	D1	E	F	G	H	I	L	Weight
2000 A	100	20	50	M42x3	Ø 14	25	58	45	55	80	195	4.3 kg
3150 A	120	20	60	M48x3	Ø 14	30	68	45	55	80	220	5.6 kg

250 A

2-009 Type

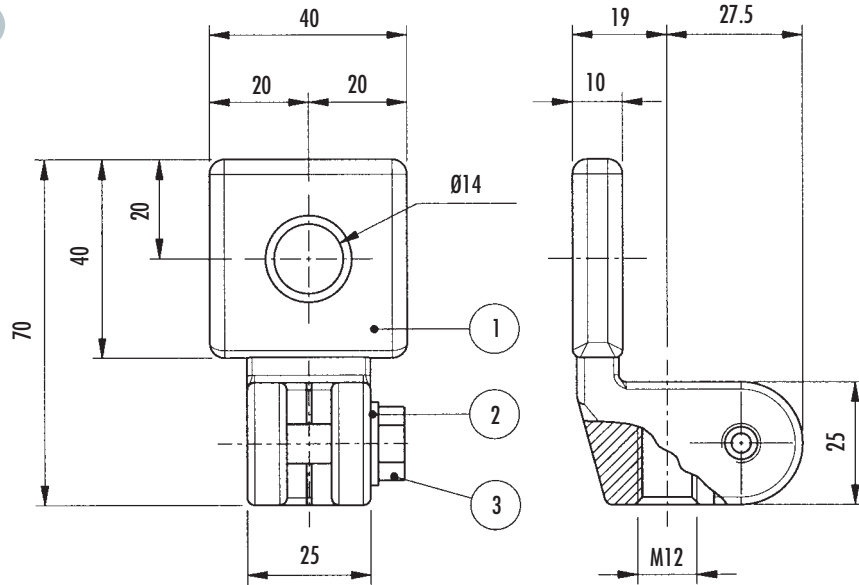

ITEM	DESCRIPTION	Q.TY
1	FLAG	1
2	WASHER DIN 125 A	1
3	SCREW DIN 933	1

630 A

AF 06 Type

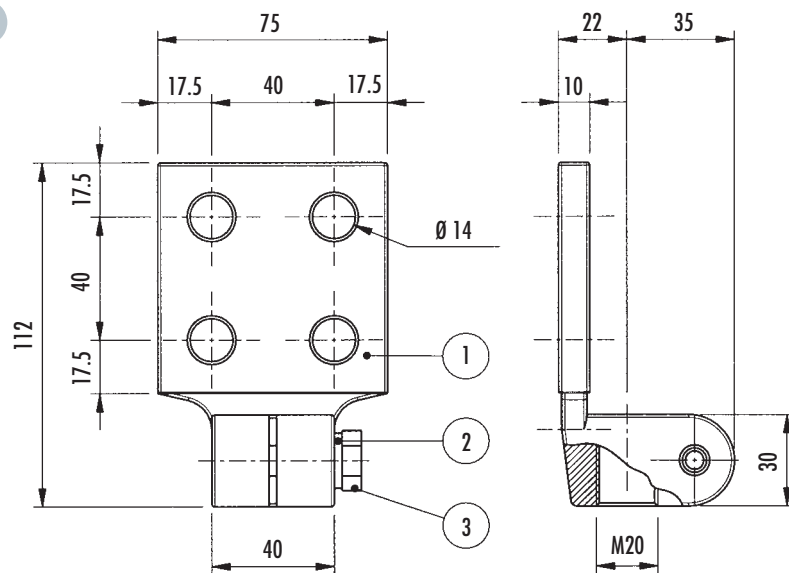

ITEM	DESCRIPTION	Q.TY
1	FLAG	1
2	WASHER DIN 125 A	1
3	SCREW DIN 933	1

1000 A

AF 1 Type

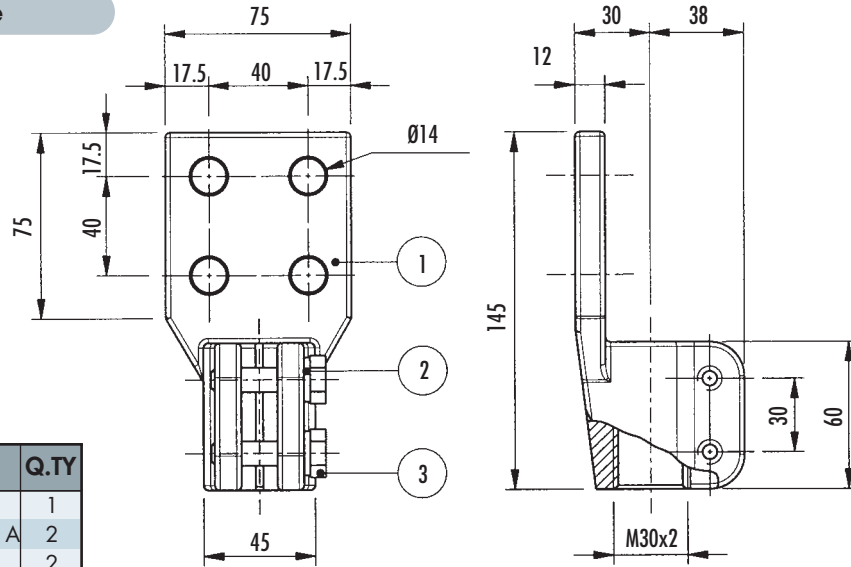

ITEM	DESCRIPTION	Q.TY
1	FLAG	1
2	WASHER DIN 125 A	2
3	SCREW DIN 933	2

10-086 Type

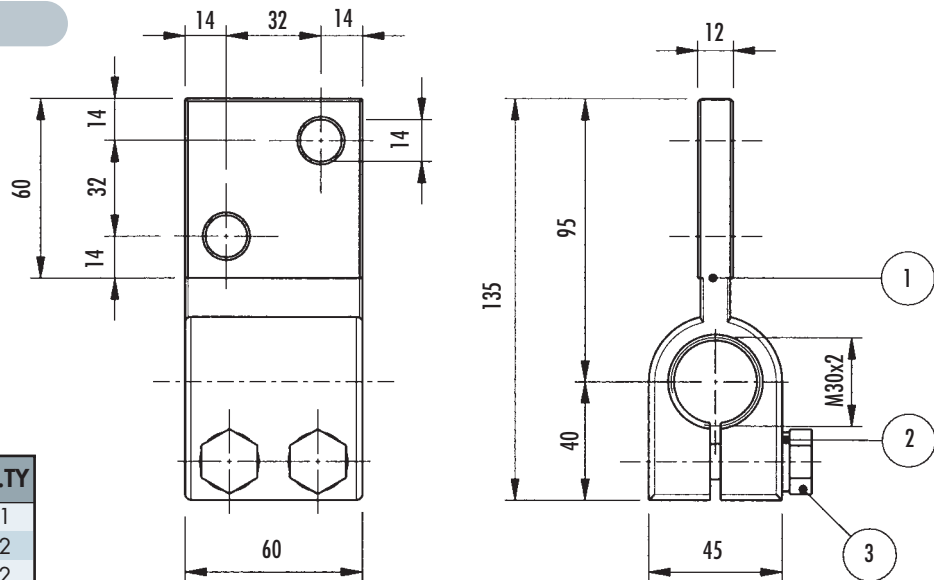

ITEM	DESCRIPTION	Q.TY
1	FLAG	1
2	WASHER DIN 125 A	2
3	SCREW DIN 933	2



COMEM

2000 A

AF 2 Type

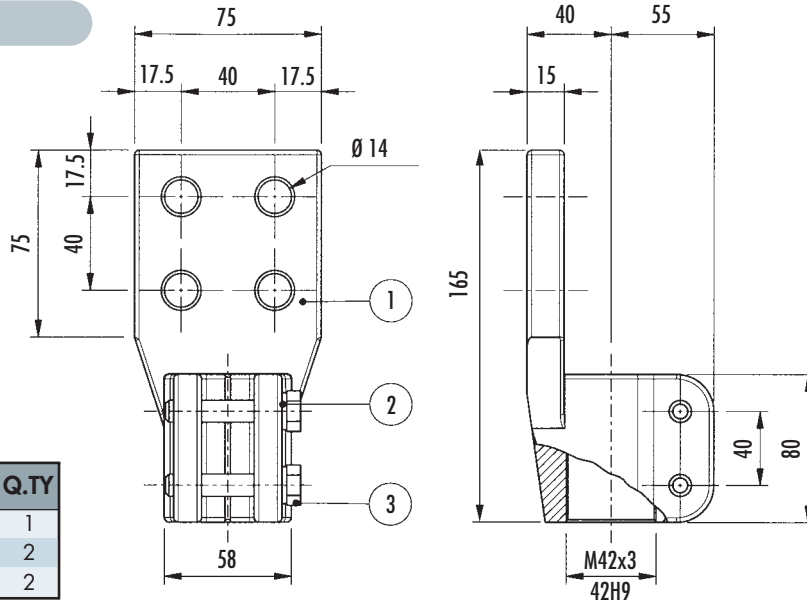

ITEM	DESCRIPTION	Q.TY
1	FLAG	1
2	WASHER DIN 125 A	2
3	SCREW DIN 933	2

20-072 Type

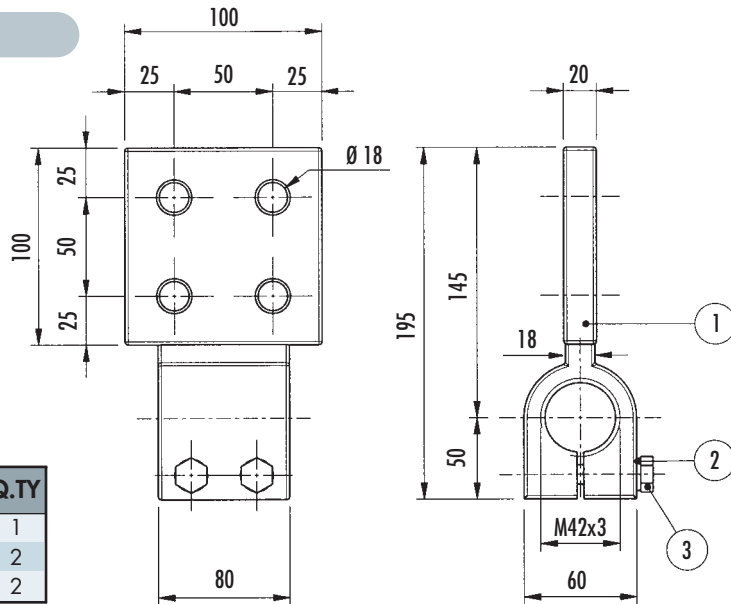

ITEM	DESCRIPTION	Q.TY
1	FLAG	1
2	WASHER DIN 125 A	2
3	SCREW DIN 933	2

3150 A

AF 3 Type

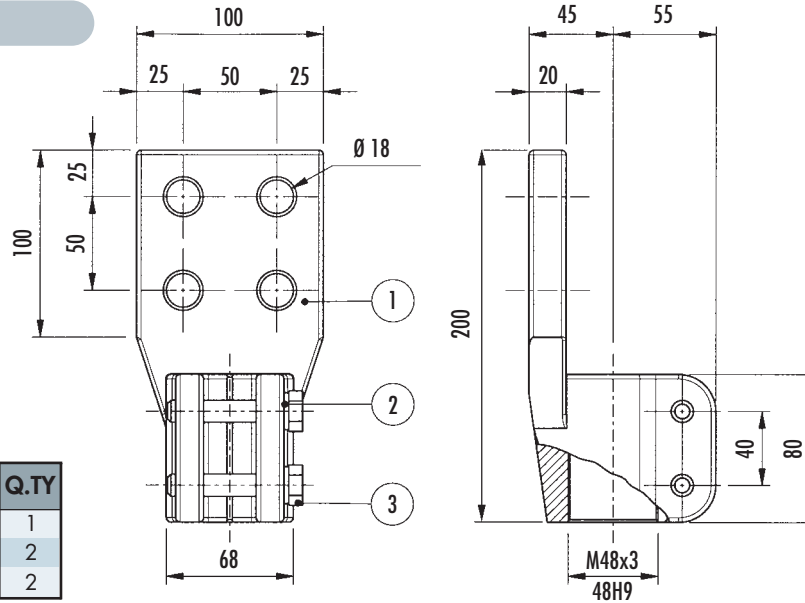

ITEM	DESCRIPTION	Q.TY
1	FLAG	1
2	WASHER DIN 125 A	2
3	SCREW DIN 933	2

31-073 Type

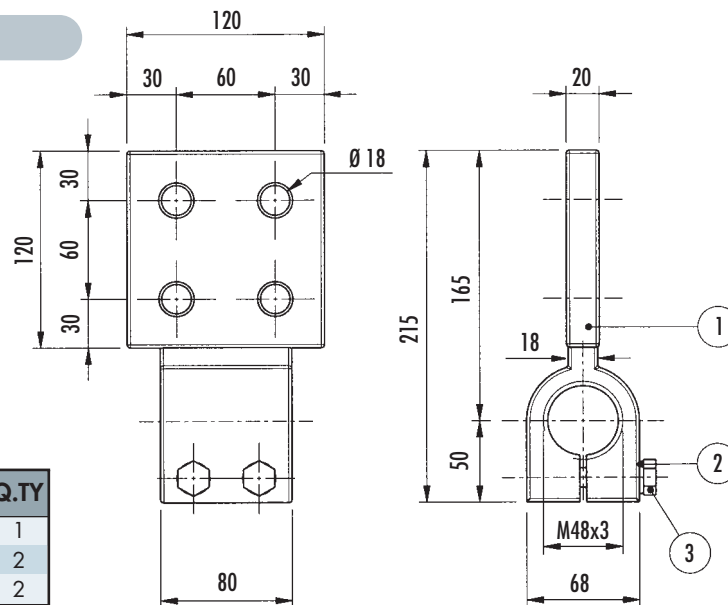

ITEM	DESCRIPTION	Q.TY
1	FLAG	1
2	WASHER DIN 125 A	2
3	SCREW DIN 933	2

4500 A

4500 A Type

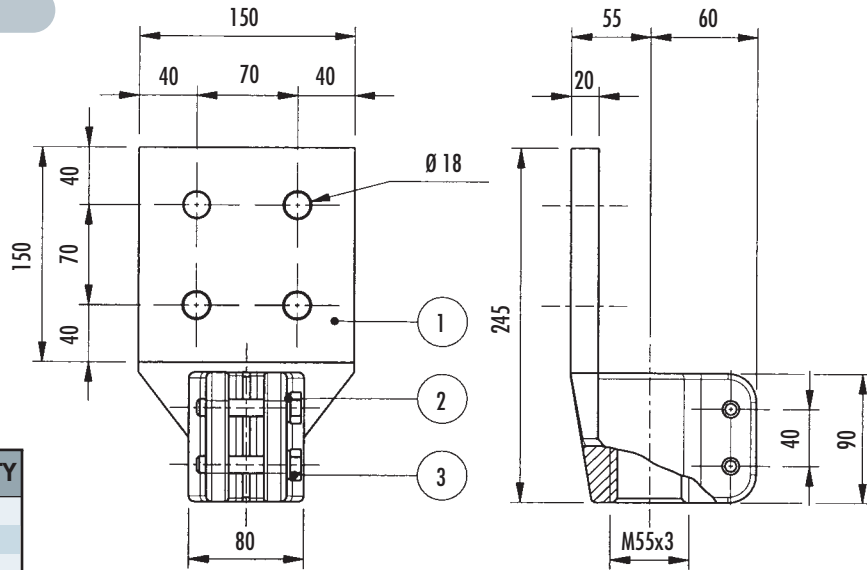

ITEM	DESCRIPTION	Q.TY
1	FLAG	1
2	WASHER DIN 125 A	2
3	SCREW DIN 933	2

4500 A

FR Type

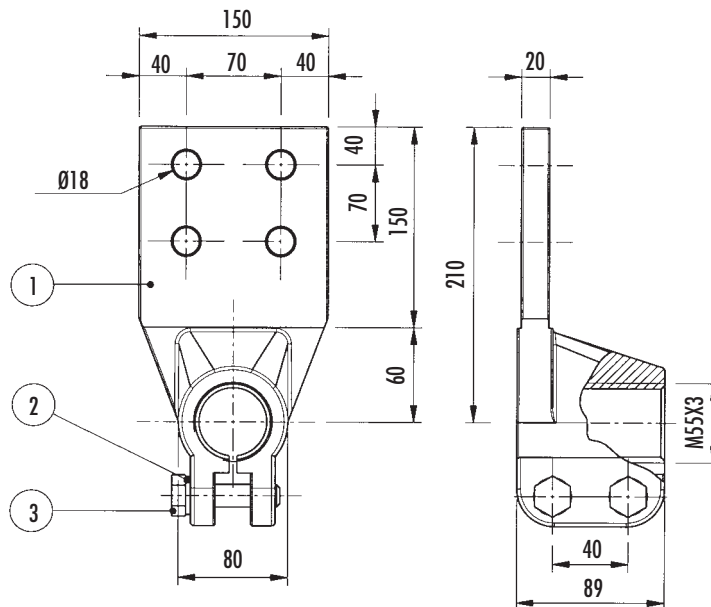

ITEM	DESCRIPTION	Q.TY
1	FLAG FR	1
2	WASHER DIN 125 A	2
3	SCREW DIN 933	2

UPPER FLAG 6300 A

U 6300 A Type

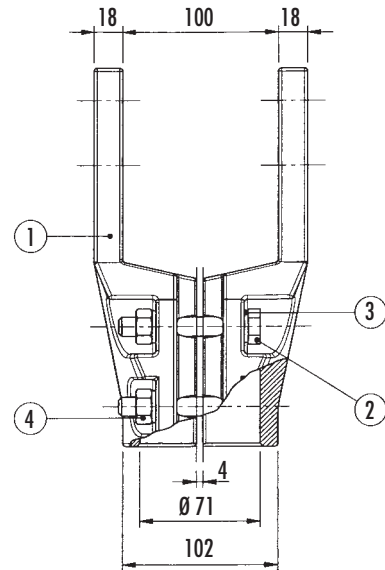
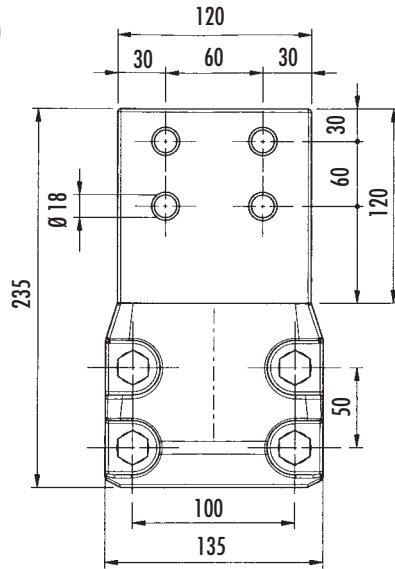

ITEM	DESCRIPTION	Q.TY
1	HALF-FLAG	2
2	WASHER DIN 125 A	4
3	SCREW DIN 933	4
4	FULL NUT	4

LOWER FLAG 6300 A

L 6300 A Type

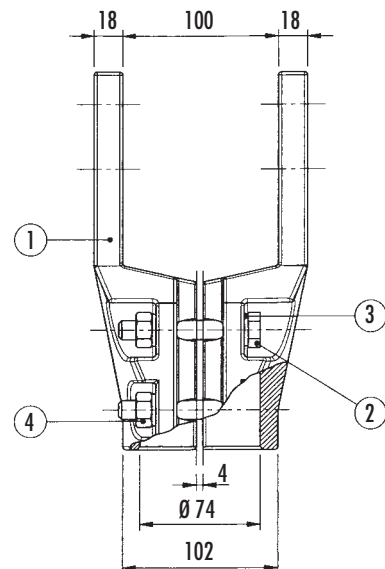
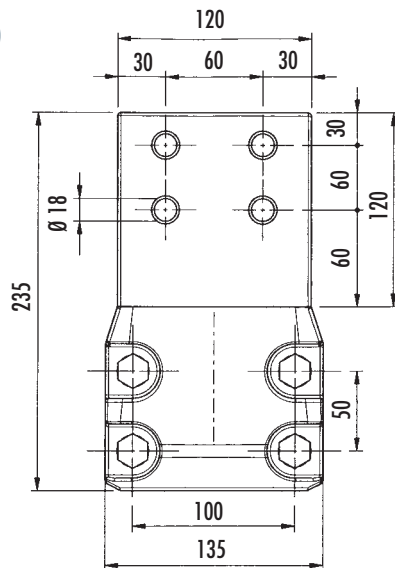

ITEM	DESCRIPTION	Q.TY
1	HALF-FLAG	2
2	WASHER DIN 125 A	4
3	SCREW DIN 933	4
4	FULL NUT	4

5000 A

TP 5000 A Type

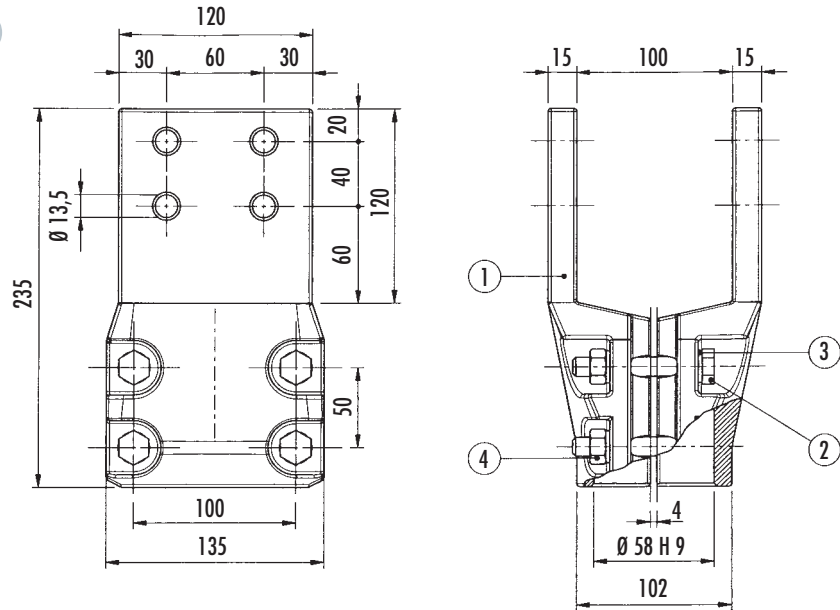

ITEM	DESCRIPTION	Q.TY
1	HALF-FLAG	2
2	WASHER DIN 125 A	4
3	SCREW DIN 933	4
4	FULL NUT	4

5000 A ÷ 6500 A

6500 A Type

5000 A Type

Current	D
6500 A	M75X3
5000 A	M64X3

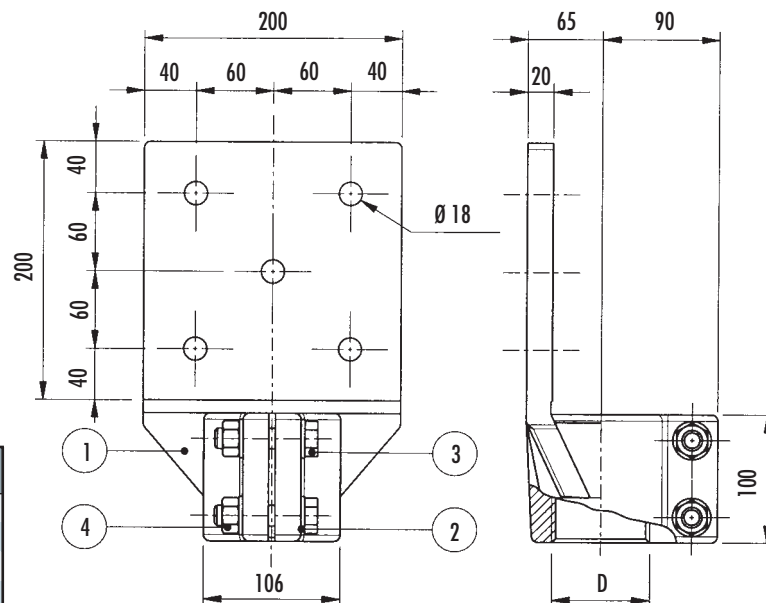

ITEM	DESCRIPTION	Q.TY
1	FLAG	1
2	WASHER DIN 125 A	2
3	SCREW DIN 933	2
4	FULL NUT	2

NOTES

A series of horizontal dotted lines for writing notes.



comem[®] - S.p.A

Strada Statale 11, Signolo 22
36054 MONTEBELLO VIC.NO (VI) ITALY
Tel. 0444 449 311 • Fax 0444 449 352 - 440 359
Internet <http://www.comem.com> • e-mail: comem@comem.com

Due to technical improvement of our products, the information contained in this catalogue may be subjected to change without notice.